

CIRCON 107 – The electronic circulation controller for DIN Rail

Dear customer,

You wish to make your own contribution to a responsible handling of energy resources and at the same time reduce your running costs of operation. This is why you have chosen CIRCON – a top-quality piece of equipment controlled by a microcontroller with the most progressive recognition and control algorithms which will release you in future from any further concerns regarding practical operating hours of your hot water circulation pump.

Upon commissioning, the device will automatically adjust to your existing hot water system and your consumption habits. In order to ensure proper functioning and that you enjoy your device from the start, we request you to carefully observe the following few, but very important installation and operating instructions.

If you are interested in further details and current information, we additionally recommend reading our homepage at <http://circon.dr-clauss.de>.

Functional description

Each hot water circulation system forms a cycle from the water heater via the riser to the tap (water tap, mixing battery) and via the circulation lines from the taps back to the water heater. A circulation pump keeps the water moving within this cycle and thereby prevents it from cooling down. In this manner, there is always hot water available at all taps. This comfort is "paid for" by constant dissipation of heat to the environment and by consumption of electric energy for the continuous operation of the circulation pump, although hot water is required only occasionally during the day.

CIRCON switches on your circulation pump only when required in two overlapping operating modes:

- 1) Random request, i. e. after short-time opening of any of the hot water valves in the house: Despite the fact that the valve has meanwhile been closed again, hot water will be available after a short time. Depending on the pipe installation and pump capacity, the inevitable waiting time can be several minutes.
- 2) Look-ahead circulation: When regular daily consumption habits have been recognised, CIRCON will automatically start in advance, thereby avoiding unnecessary waiting times. Thus, CIRCON keeps "learning" constantly and continuously adjusts the look-ahead running times to the actual tapping times. If particular habits are abandoned, CIRCON of course "forgets" them again, too.

In order to be able to safely record tapping operations in the house, the smallest changes in temperature on the riser are evaluated; for this purpose, a temperature sensor must be carefully installed there.

In order to be able to restrict the running times of the pump to a minimum for a sufficient supply of all taps, the circulation line is monitored by another temperature sensor.



You have the possibility to determine yourself the compromise between the best savings effect and highest comfort by means of an adjusting slot for screwdrivers on the front panel of the device. In central position (condition as delivered, see direction arrow), both are well-balanced. The more it is turned to a higher position up to 9, the more comfort prevails, i. e. also more rarely observed habits are learned faster and remain valid for a longer period without refreshing. Another consequence is that at times with occasional hot water requests at distributed intervals – e. g. during the daily housekeeping times – the pump switches on and off at seemingly random intervals, so that a medium temperature is maintained. When turning the slot to a lower position down to 0, the savings effect increasingly prevails, i. e. only regularly returning, more time-dependent habits are learned.

If the habits in the weekends are clearly different, the device will recognise this automatically. During these times, look-ahead pump operations are blocked.

In case of prolonged absences, e. g. during holidays, pump operations are completely stopped at the latest after 18 hours, until the first inhabitant “reports back” by tapping water. Then the already learned rhythm of habits is immediately reactivated.

An integrated disinfection synchronization ensures regular rinsing of the piping system at maximum water heater temperatures and thereby prevents Legionella and other micro-organisms from multiplying.

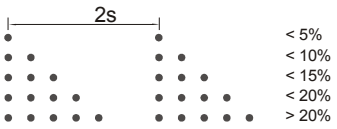
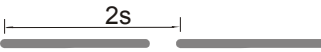
A multi-coloured LED display indicates the operating state or errors of the device:

State	Flashing sequence	Colour (sequence)
Pump not runs:		
Idle / Ready	Number of flashing pulses indicates operating statistics (With absence 4 sec.). 	green
Circulation warmed up, pump run not necessary		orange
Idle / Ready – but battery low.		red
Protection-off: Water not warmed up or Error „Dry-running“		red
Pump runs:		
Circulation on request	Two-coloured sequence 	green – orange
Habitual circulation		orange – green
Sterilisation run		green – red
Direct pipe sensor error		red

Consequently, the average percentage operating time of the pump for the past days can be determined in „Ready“ state. In doing so, more importance is attached to recent operating times than to older ones.

Example:

2 flashing pulses within a period of 2 seconds means 5...10%, i. e. approx. 1.2...2.4 hours operating time within 24 hours.

General description

The control device CIRCON 107 (figure 1) is intended for mounting on DIN rails in lockable control cabinets (box) and is connected to all external cables via two pluggable and distinctive terminal strips – one for mains-connected and one for mains-isolated circuits.



Figure 1 – Control Device CIRCON 107

The external wiring diagram is shown in figure 2. The installation and wiring of the control device must be performed by instructed and qualified electricians, who are familiar with this kind of work. A professional mounting and wiring in accordance to regulations has to be applied. The technical specifications, especially the indicated limits, have to be considered and must not be exceeded - even not for short periods.

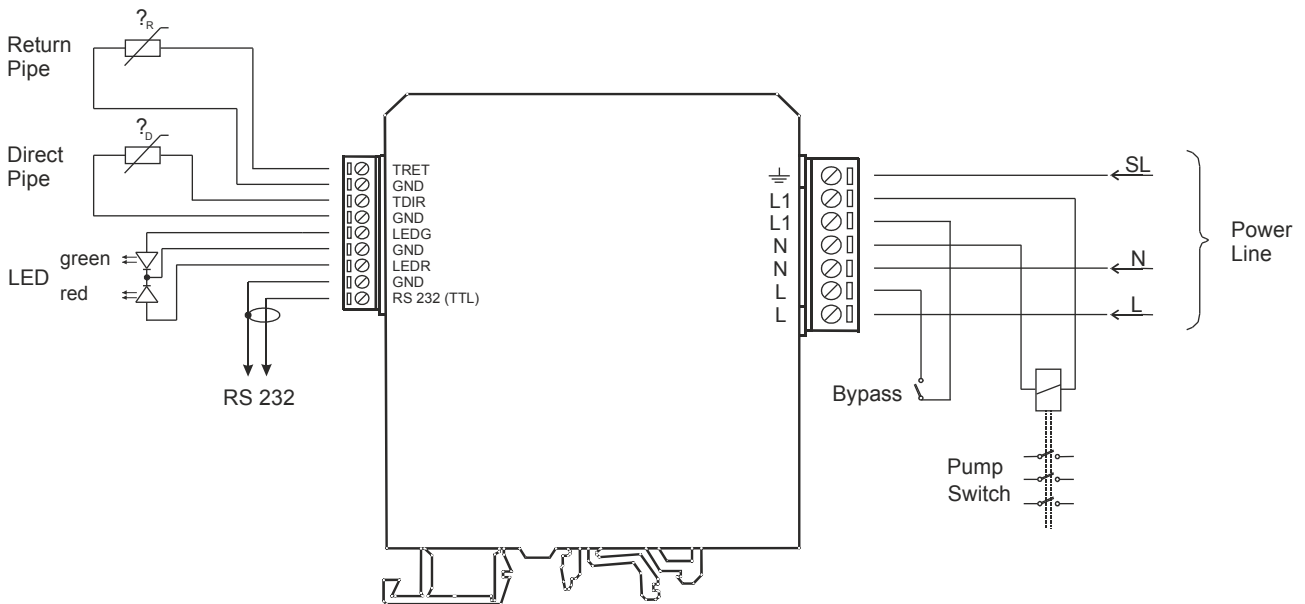

Figure 2 – Wiring Diagram

Description of mains-connected circuits:

The switching output L1 is not intended for the direct connection of the circulation pump but for the control of an electric contactor, which performs the 3-phase or 1-phase switching of the circulation pump.

The operating voltage input (Power Line L, N) is intended for 1-phase mains supply with a 230 V nominal AC voltage and a 50 hertz frequency. Instead of a mains switch for the control device, we recommend the use of a circuit breaker, which also disconnects the control circuit of the contactor from the mains voltage, if it is needed.

To turn the circulation pump into a continuous operation mode – independently of the state of the control device – further contacts L, L1 for a bypass switch are available. Of course, they can also remain unused.

The protective conductor terminal SL is connected to the GND potential of all mains-isolated circuits.

Description of mains-isolated circuits:

Our pipe sensors RFY-83, which are connected between TDIR (Direct Pipe) resp. TRET (Return Pipe) and GND (Ground Potential), were used as temperature sensors.

To control a two-coloured LED (red/green) for the status display at the optional control panel of the box, a 3-pin connection LEDG (anode green), LEDR (anode red) and GND (cathode) is intended. The operating states of this optional external LED is displayed synchronously direct at the CIRCON 107.

A serial interface, which is compatible to the RS232 protocol, provides every 5 seconds the temperature values of both temperature sensors in °C, the switching state of the circulation pump and the operation statistic in %. A shielded cable for noise suppression of this output has to be used.

A ten-steps rotary switch, for selecting the appropriate comfort level between 0...9, and a three-coloured indicator for the current state are located on the front panel.

A backup battery, which is easily replaceable from outside, guarantees the data retention of the circulation controller and the continuous operation of the internal real-time clock even during power outtages. By this the immediate resume to normal operation state without implications is assured. The operation without or with empty backup battery is possible without restrictions. If there is a power outage in this case, the device will reset when it is switched back on again.

Scope of supply

Basic device, 2 temperature sensors with red and blue markers for riser and circulation line respectively.

Installation



Important ! Read and observe safety hints before starting the installation !

Selecting the temperature measuring positions

The appropriate selection of the installation position and correct attachment of the temperature sensors is of decisive importance for the proper functioning of the device.

Identifying the appropriate pipes on the hot-water storage tank:

- 1) All pipes directly connecting the hot-water storage tank to the heating and hot-water boiler or heating circuit should not come up for closer consideration.
- 2) Characteristic features of the flow pipe (riser, **red marked sensor**):
 - is usually not connected to the top side of the hot-water storage tank
 - is not directly connected to the cold-water pipe
 - is not fitted with a pump
 - in most cases, a three-way mixer valve (thickened T-piece) is installed
- 3) Characteristic features of the return pipe (circulation line, **blue marked sensor**):
 - may be connected to the hot-water storage tank from the side or from the top
 - has often a smaller cross-section than the flow pipe
 - is fitted with the circulation pump

4) To be on the safe side:

- feel the temperature on the pipes coming into question with the circulation pump running
- switch off circulation pump for about 30 min; do not withdraw hot water during this time (the two pipes of the hot-water circuit will now slowly cool down)
- switch on circulation pump again; now, first the flow pipe and then the return pipe will heat up.

Selecting the measuring position in the flow pipe:

If the sensor is fitted closer to the hot-water storage tank, the water quantity required for activating the circulation pump will be smaller. However, the temperature changes in the storage tank itself will also have a greater impact. In particular with continuous copper pipes, it is advisable to position the sensor at a sufficiently large distance from the tank. If there is a mixer valve in the circuit, install the flow sensor between the valve and the storage tank. Practical experience has shown that distances to the storage tank of about 20 to 40 cm are appropriate. With copper pipes, a somewhat greater distance, and with plastic pipes, a somewhat smaller distance should be chosen. For systems including different materials, the following applies: Prefer metal to plastics and thin-walled to thick-walled parts for fitting the sensors. (Further useful hints can be found at <http://circon.dr-clauss.de>). The measuring point in the return pipe is not critical, but it should be located as far away as possible from the hot-water storage tank.



Important! If you have changed the locations at which the sensors have been mounted you have to newly start CIRCON without battery.

Attaching and connecting the temperature sensors

The correct application of the pipe sensors is described at the enclosed package leaflet.

The soft, silicone-coated sensor surface is the contact surface with the pipe. It is attached to the pipe by means of the supplied wide cable ties which must be secured tightly. If required, these cable ties may also be opened and reused.

Please observe by all means:

- Sensors must be attached only with the associated wide cable ties! Do not use any other cable ties!
- Attach sensors with greatest care. An insufficient thermal contact with the pipe might otherwise call into question the proper functioning of the entire device.

Lay the connecting leads in the direction of the basic device along the pipes or pump connection line so that persons cannot become caught or trip. Tighten the supplied cable fasteners only slightly so as not to constrict the cables.

Putting into operation

When the temperature sensors have been attached and connected to the device (fig. 1, pos. 4, 5), CIRCON is inserted between the mains plug of the circulation pump and the wall socket.



Important! After putting into operation, no more changes must be made to the temperature sensors – otherwise, the device must be restarted without battery!

Already on the day after starting-up of the device, look-ahead starts of the pump are initiated at the consumption times of the previous day. In the course of the following days, the habits are more clearly distinguished from random requests. If there is a weekend with different daily habits included in this period, the formation of the final profile of habits may be additionally delayed.

We recommend keeping the central position of the adjustment slot in the beginning and to adjust in a controlled manner only after a few days of operating time and stabilisation of behaviour, if required. The automatic recognition of the weekly rhythm depends on how clearly the habits during the week and in the weekend are distinguished from each other and may take approx. 2 weeks or longer.

Maintenance

The device by itself is maintenance-free. Use exclusively a dry cleaning cloth for cleaning. Solvents or sharp-edged tools must not be used.

If a backup battery is used, it has to be replaced regularly – at the latest when the status display shows “Battery Low”. Solely the intended battery type (see data sheet) has to be used. During switching the battery the device has not to be turned off. A few seconds after inserting the new battery the errors displays changes and confirms the operational readiness.

Depending on the commonness of power outtages the battery can last for several years.

Troubleshooting

We know from our experience: Most malfunctions are caused by installation errors or are understood as such due to a wrong interpretation of the principle of operation.

How to recognise actual errors:

- LED display on the device remains dark or permanently lit – probably device error.
- Sensor error according to the table is shown, although the temperature sensor is connected – interruption or short circuit at the inlet sensor.



Safety hints

The circulation controller has been shipped from the manufacturer's works in a condition meeting all safety requirements. To ensure a safe operation, observe the following safety hints. We do not accept any liability for damage to property or personal injury caused by inappropriate handling and operation or non-observance of these safety hints.

Purpose, operating conditions

The basic device is exclusively intended, and has been approved only, for use in safety class I (with earthing contact) 230 V / 50 Hz AC grids in connection with the supplied temperature sensors and a power contactor for switching a circulation pump.

The circulation controller may not be used on human beings or animals.

The device and its accessories must not be opened, modified or reconstructed. Connecting other devices or components to the terminals designed for connection to the temperature sensors and circulation pump may cause personal injury or damage to the basic device or other equipment and is, therefore, not permitted.

The device must not be used in damp locations or outdoors or under severe environmental conditions (moisture or high humidity, dust and flammable gases, vapours or solvents, strong vibrations).



Installation

All installation works should be done by qualified electrician. Unqualified persons are not allowed to perform such works.

Install the temperature sensors so that existing devices and piping installations will not be damaged.

Special caution will have to be exercised in the proximity of installed gas lines.

The leads for connecting the temperature sensors, the circulation pump and other devices shall be laid and fastened so that they do not cause a tripping hazard or that persons may not get caught.

After a sudden temperature change, e.g. after the device has been transported or stored, allow the device to acclimatise for at least 15 minutes before putting it into operation.

Operation

Make sure that the enclosure and insulation are neither damaged nor destroyed. The circulation controller must not be covered during operation to allow its own heat to dissipate at all times!

Keep children away from electronic devices operated at mains voltage!

In commercial facilities, the accident prevention regulations issued by the association for electrical installations and equipment shall be complied with, and the protective quality shall be tested in regular intervals in accordance with VDE 0701. In schools, training facilities, DIY and self-help workshops, trained personnel shall be assigned to supervise the operation of power supply units.



Important! Where there are doubts as to the safe operation of the circulation controller, or where safe operation is no longer possible, switch off the device immediately and secure it against unintentional operation, in particular when:

- the circulation controller is visibly damaged, the temperature of the basic device rises excessively,
- or when it gives off a strong smell,
- malfunctioning of the controller occurs or the controller fails completely.

Under no circumstances may the enclosure be opened or enclosure parts removed!

Guarantee

This device is warranted by Dr. Clauss Bild- und Datentechnik GmbH within the European Union (EU) for a period of 24 months, starting with the date of purchase from a dealer (a note of purchase should be produced as evidence). Dr. Clauss Bild- und Datentechnik will rectify during the warranty period free of charge any faults caused by defective material or workmanship and will at its own discretion repair or replace the defective part. Further requests excluded. Replaced parts/devices shall become our property. The original warranty period will not be extended by repairs or replacements. Any work performed by persons not authorised by us will make the guarantee null and void. This guarantee does not cover any damage caused by improper use, non-observance of the operating instructions, tampering by third parties or events of force majeure. We do not accept any liability for consequential damage resulting therefrom. This warranty does also not cover minor defects which have only an insignificant impact on the value or serviceability of the device.

Manufacturer: Dr. Clauss Bild- und Datentechnik GmbH
Turnhallenweg 5a
D-08297 Zwoenitz / Germany
<http://circon.dr-clauss.de>
service-circon@dr-clauss.de
Fax: +49-37754-507-28