

Instructions For Use And Installation

Heat Pumps for Sanitary Water Heating

WP 450 Eco

This manual is to be handed over to the end user after installation!

ID.: 17-16-27-1514-02 / 11.2016

EN





Instructions for use and installation - Version 02 / Released on 11.2016

All previous versions of this document are void. We reserve the right to make changes. We reserve the right to change this document and for printing errors.

1. Index

1.	Index.....	3
2.	Important Information	5
2.1	Symbols	5
2.2	General Warnings and Instructions	5
2.3	Safety Warnings and Instructions	6
2.4	Obligations of the Manufacturer.....	9
2.5	Obligations of the Installer	9
2.6	Customer Support - Service	9
2.7	Obligations of the User	9
2.8	Factory Testing	10
2.9	Storage	10
2.10	Transportation	10
3.	Delivery Content.....	10
4.	Technical Description	11
4.1	General	11
4.2	Components.....	11
4.3	Operation Principle.....	13
5.	Position of Connections and Dimensions	14
6.	Installation	14
6.1	Minimal spacing of the device:	16
6.2	Device Levelling	17
6.3	Hydraulic Connection	17
6.4	Air Canal Installation	19
6.5	Connection of Condensation Outlet.....	20
6.6	Connection of External Heating Source (alternative / additional source).....	21
6.7	Placement of External Controller Temperature Probe	24
6.8	Parallel Connection of Several Devices.....	25
6.8.1	Connection to Boiler	25
6.8.2	Air Canal Connection	26
6.9	Electric Connection	26
6.9.1	Power Supply:	27
6.9.2	Additional Heat Source Connection.....	28
6.9.3	Connection of Additional Electric Heater Activation (option)	29
7.	Device Startup	29
7.1	Filling Device With Water	29
7.2	Controls Before Startup	29
7.3	Device Startup.....	29
8.	Controller.....	30
8.1	Basic Window.....	30
8.1.1	Sanitary Water Temperature	30
8.1.2	System statuses	30
8.1.3	Setting of Desired Temperature of Sanitary Water	31
8.2	Screensavers	31
8.2.1	All screensavers	31
8.3	Menu	32
8.3.1	Error Acknowledgement	33
8.3.2	Quick Water Heating	33
8.3.3	Basic Operation Programme	33
8.3.4	Temperature Deviation ECO	33
8.3.5	Temperature Deviation COMFORT	33
8.3.6	Daily Schedule	34
8.3.7	Ventilation Schedule.....	34
8.3.8	Vacation	35
8.3.9	Time.....	35

8.3.10	Backup Source	35
8.3.11	Overheating Programme - Anti-legionella	36
8.3.12	Automatic Quick Water Heating	36
8.3.13	Screen Brightness	36
8.3.14	System Information	36
8.3.15	Advanced Installation Settings	37
9.	Device Operation Setting	39
9.1	Basic Operation	39
9.1.1	Basic Operation Programmes	39
9.1.2	Additional Source	39
9.1.3	Backup Source	39
9.2	Operation With External Source	40
9.2.1	Water Heated by Device and External Source	40
9.2.2	Water Only Heated by External Source - Alternative Operation	41
9.2.3	Setting Availability of External Source	42
9.3	Additional Operation Programmes	42
9.3.1	Quick Water Heating	42
9.3.2	COMFORT Plus	43
9.3.3	Anti-freeze Programme	43
9.3.4	PHOTOVOLTAICS	43
10.	Errors and Warnings	44
10.1	Warnings	44
10.2	Errors	45
10.3	Errors of the OPTITRONIC 2 - WEB module (option):	46
11.	Removal and Disposal	47
12.	Maintenance and Care	47
13.	Errors in Operation	47
14.	Electrical Connection Scheme	47
15.	Technical data	49

2. Important Information

The manuals describe the process of installation and maintenance of the device. The installation and maintenance can only be performed by qualified personnel. Read the manual carefully before the installation, this way you will be informed about the intended use, functionality and process of handling the device.

- ▶ The manual has to be handed over to the end user after installation.
- ▶ In case the product is given for use to a third person, the manual has to be handed over to them as well.

Explanation of Terms

- ▶ An informed person is a person who reads this manual.
- ▶ A trained person has a certificate of professional training.
- ▶ An authorised service technician has been trained and authorised to service and perform maintenance on the device by the manufacturer.
- ▶ The user is the one using the device for its intended purpose.
- ▶ The installation technician is a professional, trained to carry out machine or electrical installation work and the installation of the device.

Inappropriate handling of the device can cause a defect of the device, injuries to the user or property damage. To limit risks, the manual uses symbols to emphasize important information.

2.1 Symbols

When installing, performing maintenance or using, various levels of danger may occur. In certain parts of these instructions, you will find warnings, with which we wish to ensure the safety of the user, remove the potential dangers and ensure the proper operation of the device.



These symbols mark various risks for the user or the device.

DANGER: Risk of situations which can lead to serious physical injuries.

WARNING: Risk of situations which can lead to minor physical injuries.

CAUTION: Risk of situations which can lead to damage or malfunction of the device.



This symbol marks information for the user.

NOTE: A notice holding important information regarding requirements of the manufacturer and the device.

2.2 General Warnings and Instructions



NOTE

Before beginning the installation read the installation and operation manual.

NOTE

Any modification or replacement of original components of the device makes the guarantee of the manufacturer for safe and functional operation null and void. In any case of improper use of the device or uses it was not intended for, the manufacturer is not liable for consequences and will reject any claims. Injuries and damage to the device or other property due to improper use are the explicit responsibility of the user alone.



**NOTE**

Device installation must be carried out in compliance with instructions or the warranty is null and void.

**NOTE**

When designing, projecting, installing and using the device, it is obligatory to take all technical data, warnings and notes from this manual into consideration.

**DANGER**

Failure to follow instructions and good practices when performing the electrical connection of the device may cause severe injuries and death.

**WARNING**

This device is intended for use in houses. Use of the device in hotels, stores, farms, light industry and other public buildings is permitted to experts or properly trained personnel.

**WARNING**

Electrical connection of the device may only be carried out by a trained installation technician for electric installations.

2.3 Safety Warnings and Instructions

**WARNING**

The device must not be placed where there are harmful substances, which could damage it, in the air (barns, dangerous substance storage, open air, etc.).

**WARNING**

The inflow pipe must obligatorily be equipped with a safety valve with nominal pressure of 0.6 MPa (6 bar), which prevents pressure increase in the water heater above the nominal pressure.

**WARNING**

Transportation of the device is only permitted in upright position.

**WARNING**

The water heater is intended for potable water storage, so it must obligatorily comply with valid national regulations on potable water, or the device could get damaged and the validity of warranty nullified.

**WARNING**

The device must never operate without water in the hot water tank.

**WARNING**

The electrical connection of the power supply cable must be carried out by a qualified electrician.

**WARNING**

Connection of the device to the power grid must take place in accordance with standards for connection to electrical grids. The device must be connected to the electrical grid via a shutdown element, built into the electrical installation according to valid regulations. The shutdown element must separate all contacts under the conditions of overload category III.

**WARNING**

Water from the device is drained through the inflow pipe of the water heater. For this purpose, it is recommended to add a special link or drain tap between the safety valve and the inflow pipe.

**WARNING**

To ensure proper operation of the safety valve, carry out regular annual controls of valve operation. If required, clean limescale and make sure that the safety valve is not blocked.

**WARNING**

Water may drip from the release pipe of the overflow. The pipe must be exposed to outside air. Should you add a valve to the pipe, it has to be turned downwards, so that the water in it cannot freeze.

**WARNING**

It is forbidden to play with the device. Children are strictly forbidden from cleaning the device without supervision.

**WARNING**

The device may be independently used only by person, familiar with the safe operation and understanding possible dangers of the device. Children above 8 years of age and persons with reduced physical and mental abilities, or with the lack of experience and knowledge, may only use the device under supervision of an instructed person.

**WARNING**

During operation, it is forbidden to move, shift, clean or repair the device.

**WARNING**

Cleaning and maintenance of the device is forbidden to unsupervised children.

**WARNING**

Before installation and any later intervention in the device, always comply with instructions for safe use and maintenance.

**WARNING**

Installation must be carried out in compliance with the valid regulations and according to the instructions of the manufacturer, by a professionally trained person.

**WARNING**

The device must not be stacked or have items lean against it. If, while the device is operational, the water temperature exceeds 85 °C, contact service.

**WARNING**

Ensure, that the device does not represent a danger to anyone. Access to device must be prevented to children and uninstructed persons.

**WARNING**

Do not place the device into a room where it could not be removed from. Later building around it or placement of other obstructions by the device is forbidden.

**WARNING**

Service and maintenance of the device may only be carried out by a service technician, authorised by the manufacturer. In case of a defect, first contact the installation technician that installed the device.

**WARNING**

Never clean the device with cleaning agents which contain sand, soda, acid or chlorides, as they can damage the surface of the device.

**WARNING**

The device contains the refrigerant R134a, which, compliant with the Kyoto Protocol, is listed among greenhouse gasses. Thus work on the device is only permitted to authorised persons for handling of refrigerant as defined by the law in force. During interventions into the device, escape of refrigerant into the atmosphere must be prevented.

**WARNING**

In avoidance of dangers, a damaged power cable may only be replaced by the manufacturer or an authorised installation technician.

2.4 Obligations of the Manufacturer

The manufacturer guarantees that the device is compliant with valid European directives and standards. The device is marked with the CE mark and has all required documentation.

We reserve the right to change instructions without previous notifications.

The manufacturer accepts no liability in the case of:

- ▶ Failure to follow device installation instructions.
- ▶ Failure to follow device use instructions.
- ▶ Wrong or inadequate device maintenance.

2.5 Obligations of the Installer

The installer is responsible for the installation and start-up of the device in accordance with the following:

- ▶ Read instructions for installation and use which come with the device thoroughly before installation.
- ▶ The device must be installed in compliance with the valid national legislation, directives and standards.
- ▶ First start-up must be carried out and potential initially present defects removed upon detection.
- ▶ The user must be trained to use the device and the settings.
- ▶ The user must be warned to regularly perform maintenance on the device to ensure proper operation during the entire operational life of the device.
- ▶ Operation of the entire system must be explained to the user.
- ▶ The user must be given all documentation that came with the device.

2.6 Customer Support - Service

Customer support and service while warranty lasts are provided by device manufacturer.

When submitting a service claim, we ask you to provide the following information:

- ▶ Exact name of the product.
- ▶ Serial number.
- ▶ Year of manufacture.

All required data is listed on the label on the device.



NOTE

In any case of a change or replacement of original components, forced or improper use of the device, the warranty becomes null and void. Possible expenses stemming from a service intervention are charged to the user in their entirety.

During warranty period, only the manufacturer or a service, authorised by the manufacturer, may carry out service and maintenance procedures. If that is not the case, the warranty becomes null and void.

2.7 Obligations of the User

To ensure uninhibited and efficient operation of the device, the user must take into consideration the following instructions:

- ▶ Read instructions for installation and use which come with the device thoroughly.
- ▶ Installation and start-up of the device must be carried out by a trained and authorised professional.
- ▶ Allow the authorised installer or ask them to thoroughly explain the functioning and means of operation of your device.

-
- ▶ You must ensure regular check ups and maintenance of the device by an authorised service technician.
 - ▶ Keep instructions for installation and use in a suitably dry place, close to the device.

2.8 Factory Testing

To ensure a high quality standard, all heat pumps are tested before leaving the factory in the following aspects:

- ▶ Sealing tightness of the cooling circuit.
- ▶ Watertightness.
- ▶ Airtightness.
- ▶ Electric safety.
- ▶ Functionality.

2.9 Storage

The device must be stored in a dry and clean area. Allowed storage temperature is between 10 and 45 °C, short term (up to 24 hours) also up to 55 °C.

2.10 Transportation

Before transportation, the device has to be protected with a protective foil or cardboard packaging, in order to prevent mechanical damage.



WARNING

When moving the device, it is obligatory to unplug it from the power grid.



WARNING

The device has impact sensitive parts so it is important to avoid any impacts during transportation or any instance of the pump falling.



WARNING

The mass of the device exceeds the permitted lifting mass for one person. All liability for possible personal injury, property or device damage is borne by the client.



WARNING

It is forbidden to place the device in a horizontal position.

3. Delivery Content

Delivery Content:

1. Heat pump
2. Water condensation removal pipe
3. Instructions for use and installation

4. Technical Description

4.1 General

This device is a heat pump for the heating of sanitary water in residential areas and small business premises. When heating sanitary water, the heat pump also cools the area, from which air is captured and / or returned to. The heat pump can thus along with heating of sanitary water, be used for cooling of indoor areas, whereby it has to be emphasized, that the heat pump will only cool the area, if there is a need to heat the sanitary water.



NOTE

For the highest efficiency and savings, we recommend that you use air from areas with waste heat (boiler room, laundry room, kitchen, cellar, pantry) as a heat source and that the air temperature is as high as possible.

4.2 Components

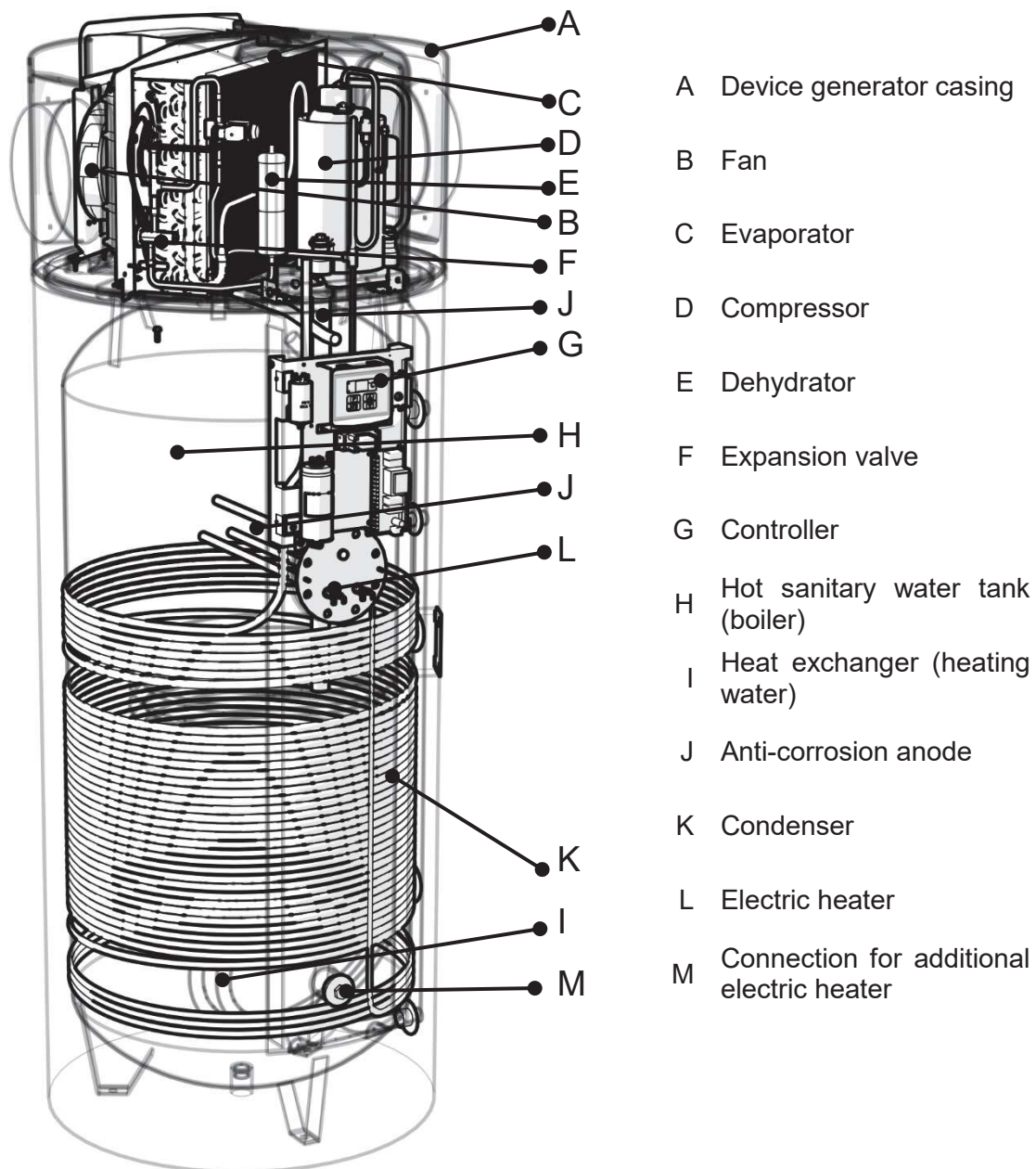

The device consists from the device generator (compressor, evaporator, fan,...) and the hot water tank. The housing of the generator is made of durable plastic and is heat and sound isolated. The device has two attachments for air channels which enable a remote air intake and exhaust from neighbouring rooms or the environment. The hot sanitary water tank is equipped with a piped heat exchanger, which can be connected to an external fossil fuel, biomass or solar energy collector powered boiler.

Hot Sanitary Water Tank

Sanitary water heater is enamelled with patented technology, heat isolated with polyurethane and mechanically protected with sheet metal. The tank is serially equipped with a water heat exchanger that can be connected with a boiler when choosing an alternative or additional heat source. An Mg anode is also placed into the tank, preventing corrosion of the heater upon potential mechanical damage to the enamel.

Electric Heater

The device is serially equipped with two electric heaters with a power of 2 x 2 kW, which serves as an additional or backup heating source.

Along with both already installed heaters, it is possible to install an additional heater into the hot sanitary water tank with a 6/4" attachment with separate power supply.

Anti-freeze probe

Regulator of heat pump senses the temperature of the vaporizer. In the case, that the temperature of the vaporizer is below -7 °C, it will perform a safety shutdown of the device for at least 30 minutes. In such a case, the heat pumps with an electric heater automatically switch to electric heating and the heat pumps with an attached boiler switch to boiler heating (circulation pump switch on).

Safety thermostat

The electric heater contains a safety thermostat with a limit at 90 °C. This means that, in the case that the temperature in hot water tank is exceeded, the power supply will be switched off and the device will stop operating. To restart the device, call authorised installation technician who must verify and remove the reason of the safety shutdown of the device.



WARNING

When heating with boiler or solar collectors, you may heat the water in the hot water tank to a temperature above 95 °C whereby the safety thermostat switches off. In such a case the thermostat has to be manually reset. To restart the thermostat, an authorised installation technician must be called.

Boiler water temperature control

Monitoring and heating of water to desired temperature is ensured by the advanced OPTITRONIC 2 touchscreen regulator.

In regards to the set up desired water heating temperature, the controller, as required, switches the compressor and fan on or off, and, under certain conditions, also switches the electric heater or circulation pump of the boiler on or off. The maximal temperature of water heating that can be set up is 65 °C. Should the temperature in hot water tank increase over 80 °C, the controller switches off all sources of heat for safety reasons.

Minimal temperature of water in hot water tank is 7 °C.

High pressure cooling system protection

To prevent pressure in the cooling system to get too high and potential damage, related to it, a high pressure safety switch is installed, which stops the operation of the heat pump in the case of pressure rising beyond a preset point.

Conditions of operation

Environment temperature must be between -7 °C and +35 °C. The air must be clean with relative humidity not exceeding 50% at +35 °C. At lower air temperatures, the relative air humidity may be higher. Devices, placed at higher altitudes above sea level may function less efficiently due to lower air pressure.

4.3 Operation Principle

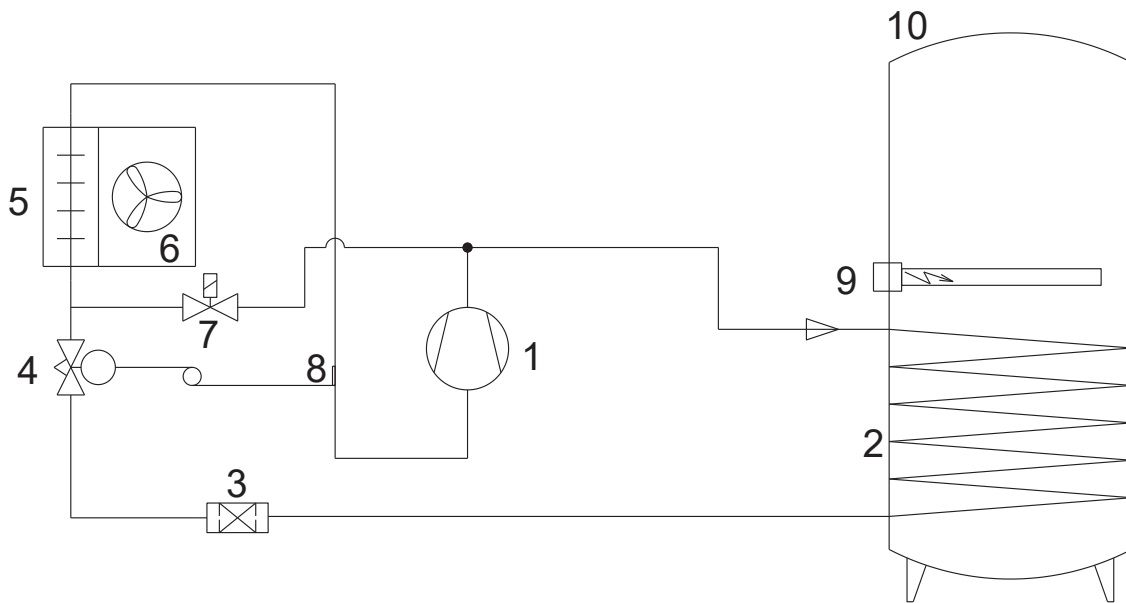

- | | |
|--------------------|---|
| 1. Compressor | 6. Fan |
| 2. Condenser | 7. Magnetic valve |
| 3. Dehydrator | 8. Temperature probe of the expansion valve |
| 4. Expansion valve | 9. Electric heater |
| 5. Evaporator | 10. Hot sanitary water tank (boiler) |

The cooling system of the heat pump is a closed circuit system, within which the refrigerant R134a circles as a heat exchanger. At lower pressure and lower temperature (e.g. 10°C), the refrigerant evaporate in the heat pump evaporator, thereby drawing heat from the air. Then, the refrigerant is compressed to a higher pressure in the compressor, which makes its temperature rise to the temperature, higher than that of the water in the boiler. The refrigerant then gives away the heat to the water in the condenser, whereby it liquefies. The expansion of the refrigerant, which makes the refrigerant pressure and temperature lower to the primary value, the circular process is concluded. This process is repeated throughout the heat pump operation time.

5. Position of Connections and Dimensions

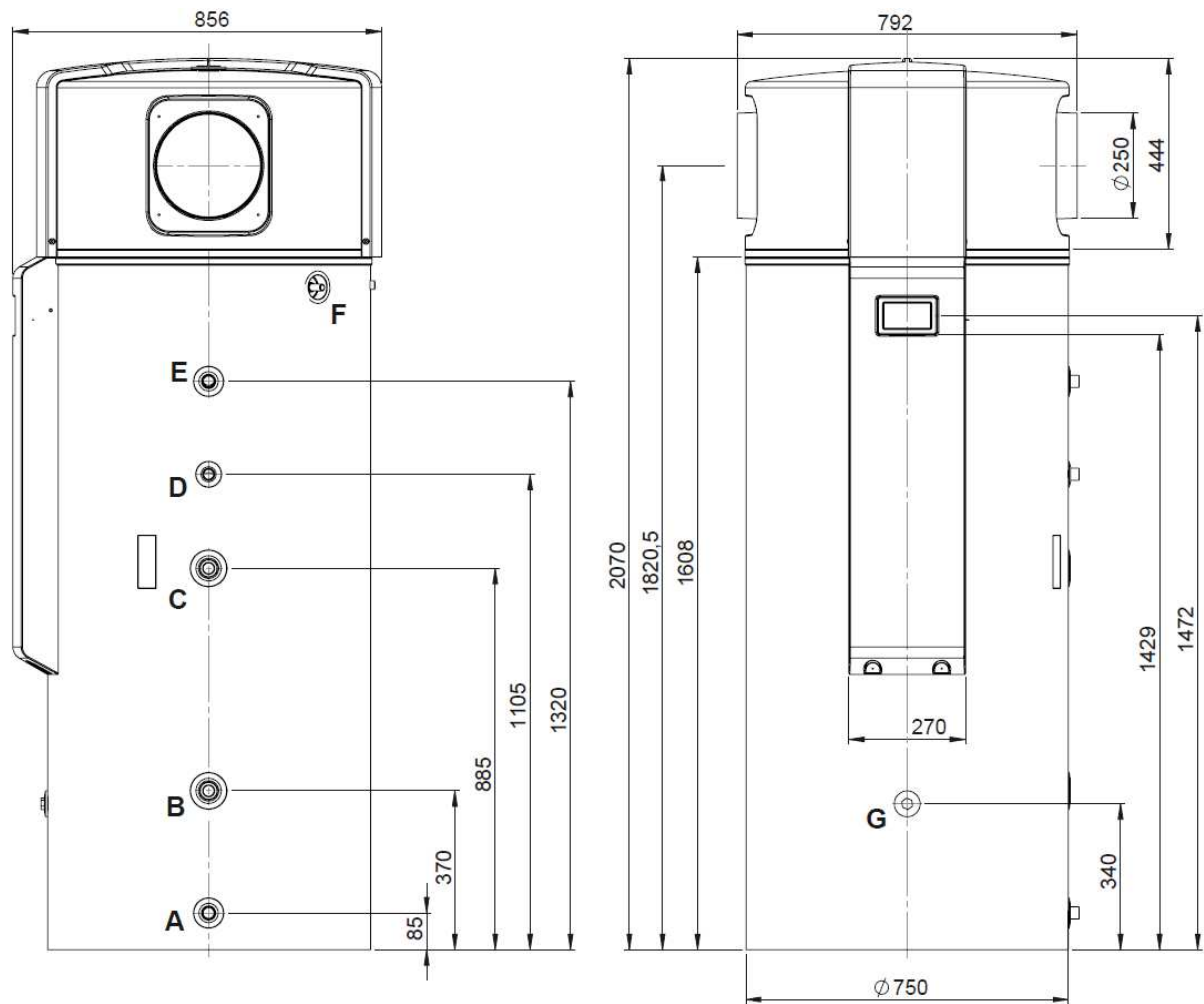

A	Connection cold water G1"
B	Connection heat exchanger - return pipe G1"
C	Connection heat exchanger – supply pipe G1"
D	Connection circulation G1"
E	Connection hot water G1"
F	Connection for removal of water condensation $\phi 16$
G	Connection for additional electric heater 6/4"

6. Installation

The lowest height of ceiling in the room must be 2500. The device is made so that it takes heat from surrounding air or sucks it through air channels and blows it into neighbouring rooms or the environment. The device may be installed in the following ways.

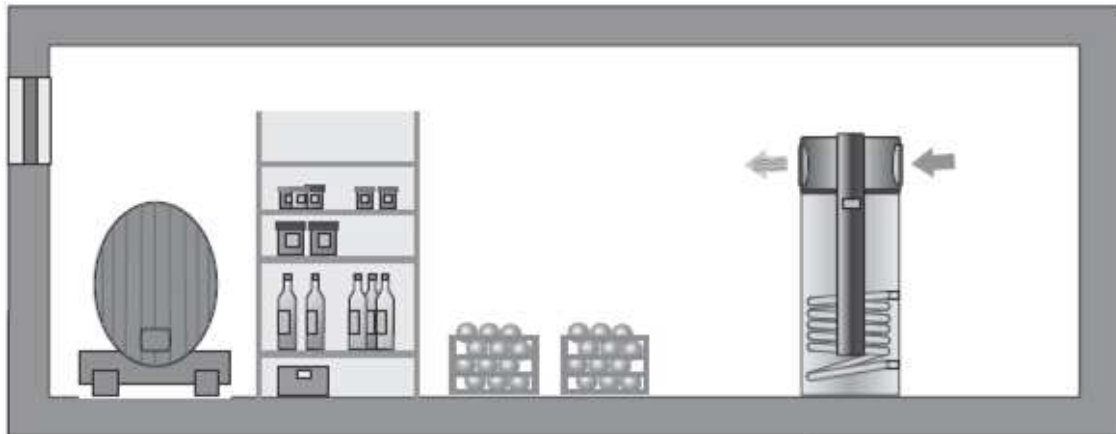

Figure 1: Suction and exhaust in the same room (e.g. pantry cooling).

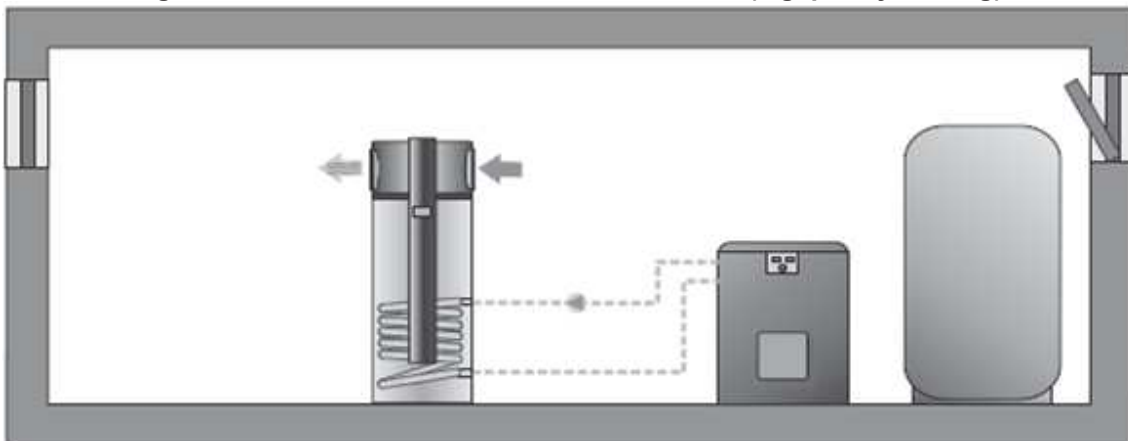

Figure 2: Suction and exhaust in the same room.

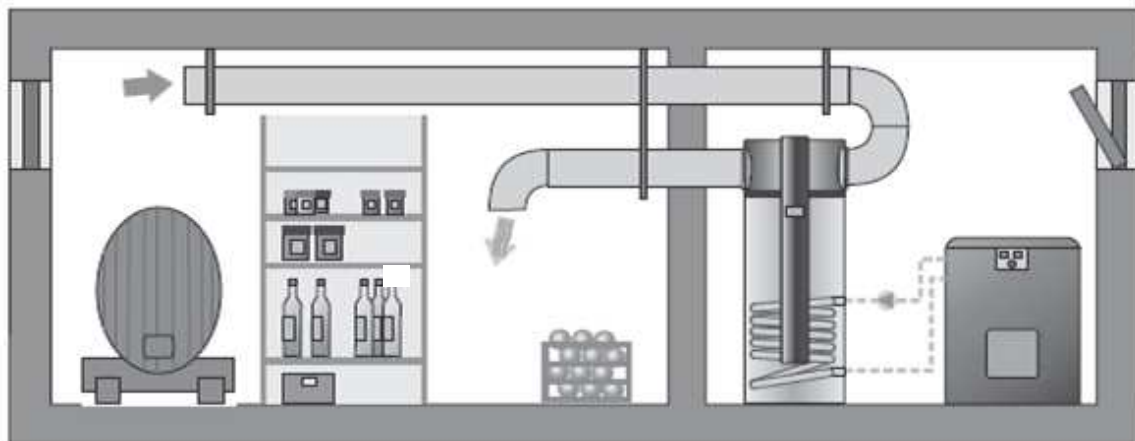

Figure 3: Suction and exhaust into neighbouring room (e.g. pantry cooling).

The most common placement of the heat pump is such, that the air is sucked from areas, where there is a lot of waste heat. This air has a part of its heat removed, then released into the surrounding. Air in kitchens, laundry rooms, sanitary facilities often contains unpleasant odours, so it is blown into the environment. Thereby we must be careful that the air flows and pressures in spaces are evened out, which must be ensured by the projecting engineer for the ventilation.



WARNING

The device must not be placed where there are harmful substances, which could damage it, in the air (barns, dangerous substance storage, open air, etc.).

6.1 Minimal spacing of the device:

The device may be placed into a room with or without installing air channels. This influences minimal spacing from the walls, which depend on the direction of entry and exit of air.

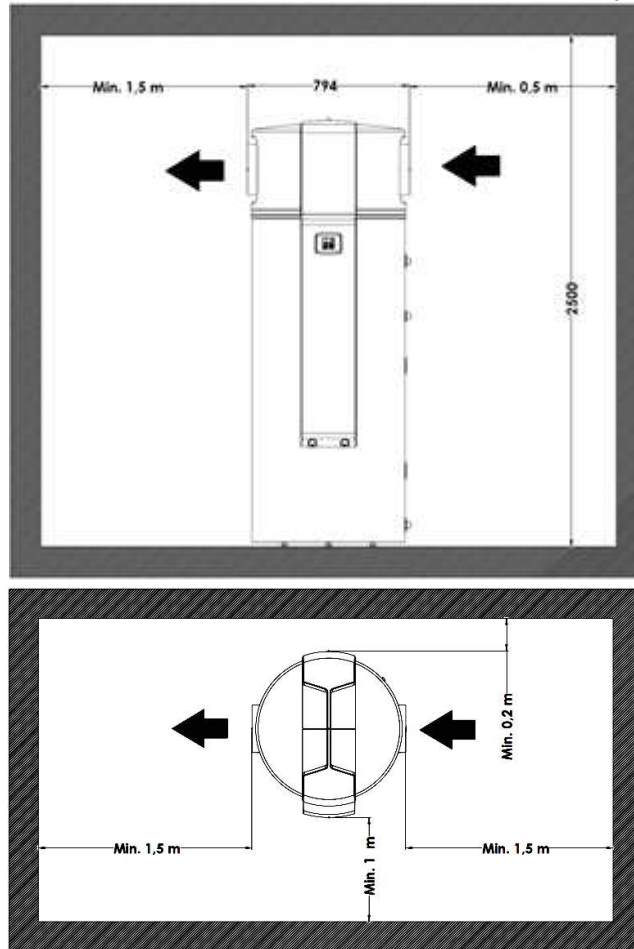

Figure 4: Minimal spacing between walls / ceiling in the case of air intake from the same room

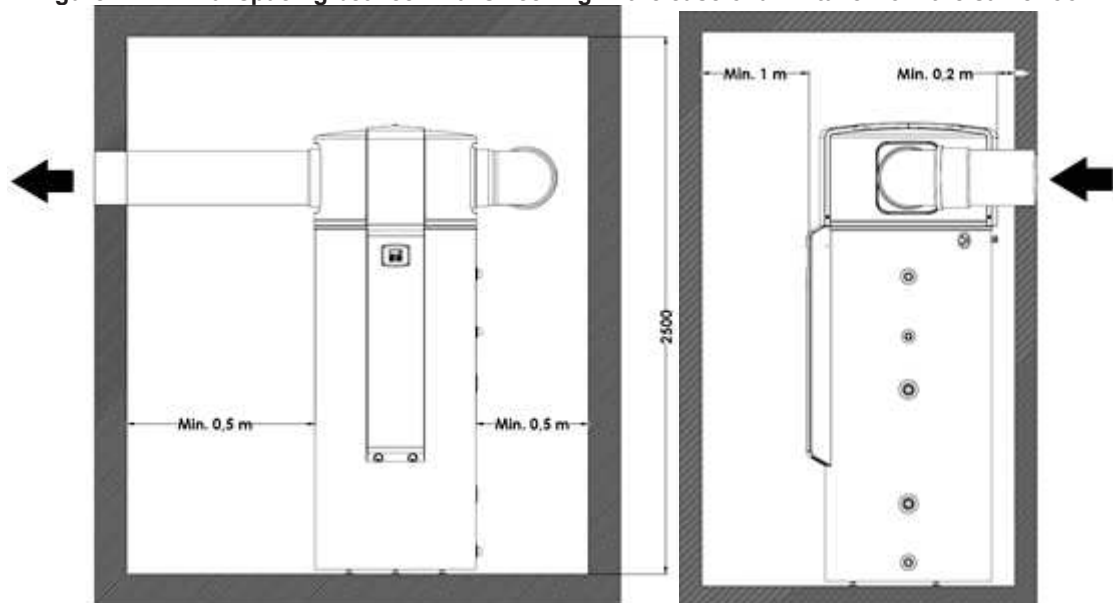

Figure 5: Minimal spacing between walls / ceiling in the case of air intake from other rooms or the environment

In the case of using air heat from the same room where the device is installed, the room must be at least 50 m³.

6.2 Device Levelling



WARNING

The device must be in a vertical position during operation to prevent potential leaking of water condensation.

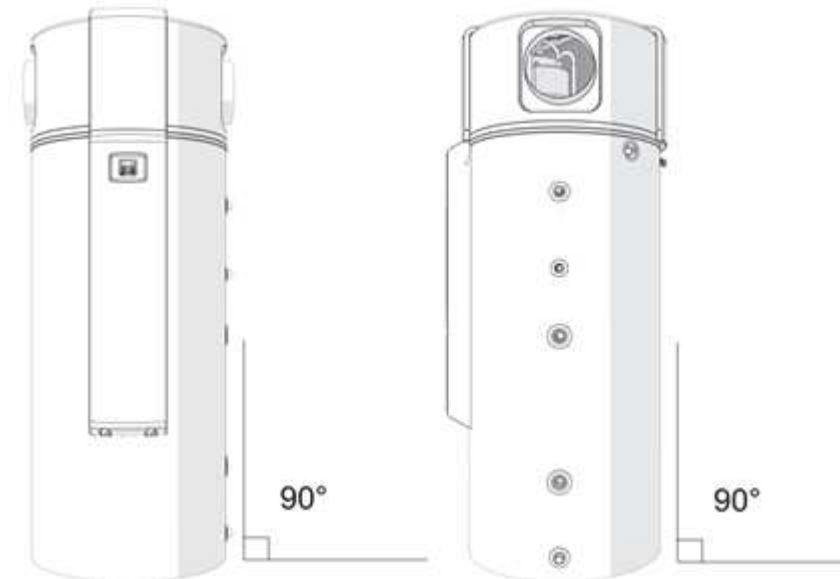

Figure 6: Device levelling

The device has to be levelled as shown on the image above.

6.3 Hydraulic Connection

Hydraulic connection must be carried out in accordance with the valid national and local regulations, which are in force for the connection of sanitary water tanks. The room with the device must have a drain below the level of the device for the drainage in the case of a water spill. The image below shows the proper hydraulic connection of the device.

Should the heat exchanger (heating water) in the water tank not be used for water heating, it must be filled with an anti-freeze liquid, to prevent corrosion in the exchanger. Only close a full exchanger at the bottom (equalisation of pressure due to temperature changes).



WARNING

Due to use of different materials on the pipe installation, all connections (cold water, hot water, circulation, heat exchanger) on the device must obligatorily be galvanically isolated, or the corrosion of connections within the heat storage may occur. We recommend galvanic separators from red alloy for each attachment, at least 2x pipe diameter in length.



WARNING

The water tank is intended for potable water so it must obligatorily comply with the valid national regulations on potable water, or device damage may occur and the warranty is nullified.

- | | | | |
|---|-------------------------|---|------------------|
| 1 | Ball valve | 5 | Expansion vessel |
| 2 | Pressure reducing valve | 6 | Drain tap |
| 3 | Check valve | 7 | Circulation pump |
| 4 | Safety valve | 8 | Device generator |

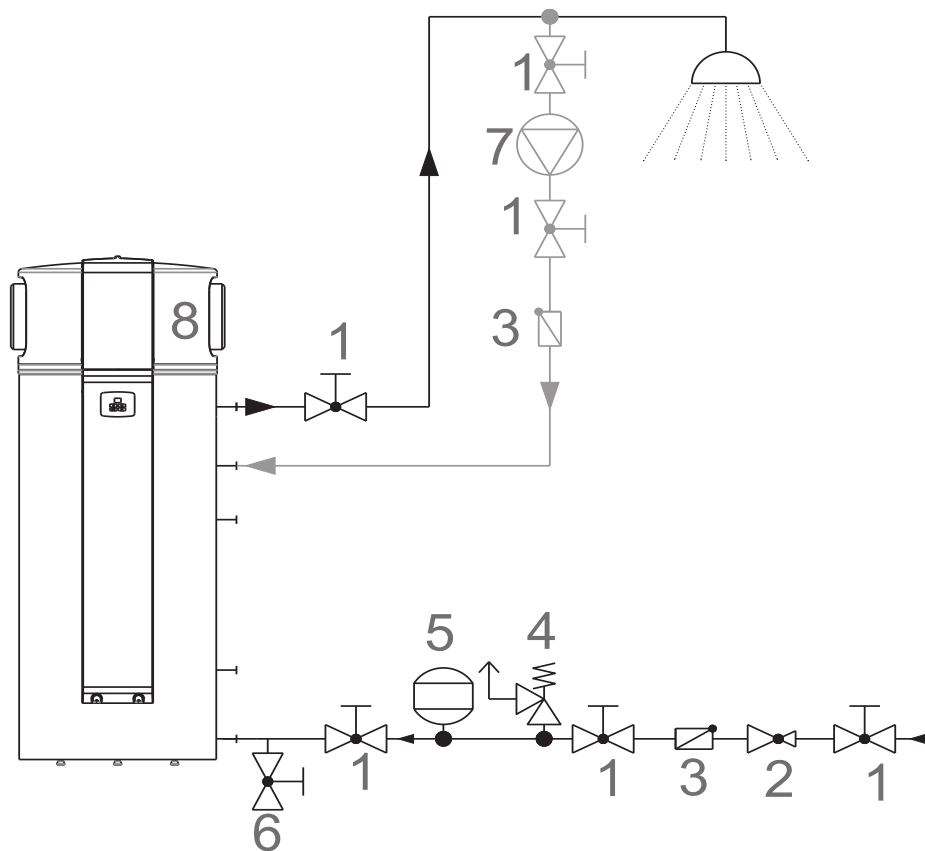

Figure 7: Connection of device to plumbing network

Dimensions of expansion vessel:

Safety valve setting [bar]	6			10		
System pressure [bar]	3,0	3,5	4,0	3,0	3,5	4,0
Volume of sanitary water tank [L]	Expansion vessel [L]*					
450	24	32	44	15	16	17

* The actual size of the expansion vessel must be set by the installation technician / planner in regards to the size of the system, in which the device will be installed.



WARNING

When installing the device obligatorily place expansion vessel into the system.



WARNING

Obligatorily install safety valve onto the inflow pipe, which has a nominal pressure of 0,6 MPa (6 bar), and prevents the increase of pressure in the hot water storage for over 0,1 MPa (1 bar) above nominal.



WARNING

For proper operation of expansion vessel, a suitable setting of the operational pressure of the tank must be made. The pressure is set in regards to the pressure in the plumbing. The setting needs to be checked every 6 months.

6.4 Air Canal Installation

The device has attachments on left and right for the attachment of air canals, which enables:

- the placement of the device into any room which is spacious enough
- ventilation of desired room
- exhaust of waste air or intake of fresh air from the environment

In the case of air canal use, keep in mind that air pipes and every additional knee represent additional air resistance and lesser capacity of the device. Table 1 shows maximal permitted canal lengths. Air canals must be isolated to prevent water condensation on the pipe surfaces. Figure 8 shows the device with air canal connections. The connections are 45 mm in length and an outside diameter of $\Phi 250$. Access to inner parts is protected with mesh.

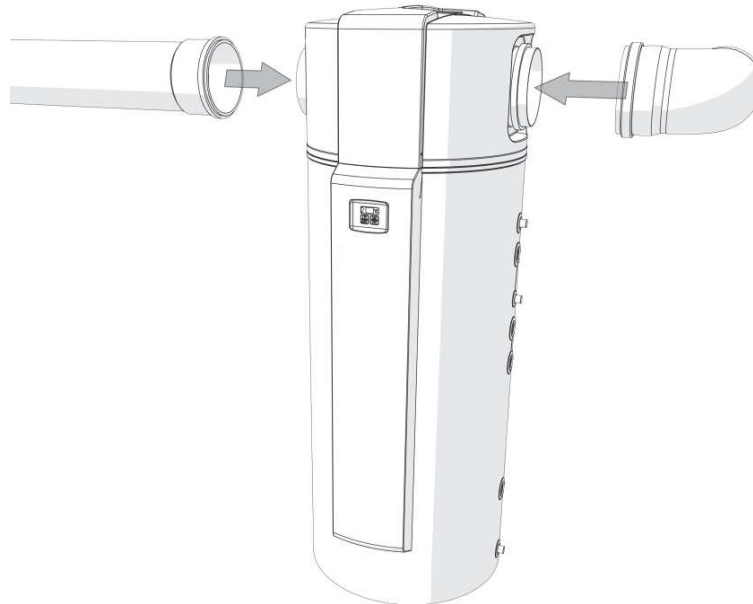

Figure 8: Air canal connection

Table 1: Maximal permitted air canal length.

Air canal diameter	Maximal air canal length
Diameter 200 mm	10 m
Diameter 250 mm	15 m

The final length of air canals needs to take into consideration also the equivalent length of accessories such as knees, reduction pieces, etc.

Table 2: Accessories

Accessories	Equivalent length in m
Knee 90° (Φ 200 mm)	3
Knee 90° (Φ 250 mm)	2
Reduction piece $\Phi 250 \times \Phi 200$	1
Wall blind	2

6.5 Connection of Condensation Outlet

By removing heat from air, condensation of air moisture also occurs in the heat pump. Depending on air temperature and relative air humidity, the production of moisture from air varies. In some cases, no moisture will be removed from air and in others, up to 10 litres of condensed water may be produced.



NOTE

When installing a condensation outlet, pay CAUTION that the pipe is always at a downwards incline with a siphon and water pillar of at least 5 cm at the outflow. This prevents the suction of unpleasant odours from outlets.

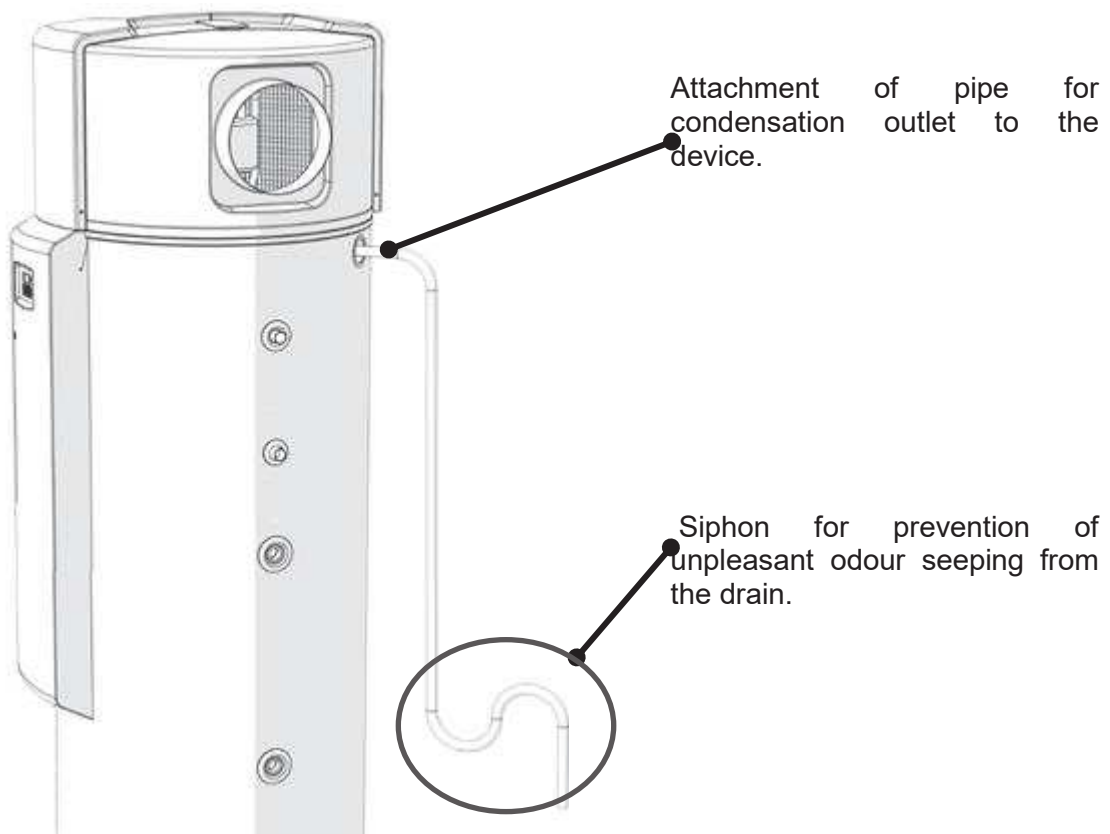

The water condensation outlet pipe must be laid in a way, where the water may always freely flow out. Connect outlet pipe with drain. Should this not be possible, ensure a collection canister, which must be regularly emptied.

6.6 Connection of External Heating Source (alternative / additional source)

Sanitary water in the water storage tank may be heated with the device generator - heat pump (primary source) and / or various external heat sources. An external heat source can heat sanitary water along with the heat pump and perform the function of an **additional heat source** or heat water independently instead of the heat pump and perform the function of an **alternative heat source**.

A **backup source** is the heat source that heats sanitary water when the machine generator does not work (defect) and there is a need for heating of sanitary water. As a backup heat source, the electric heater, installed in the sanitary water boiler, is used.

An **alternative source** is an independent heat source, which the device has no influence on, but can take advantage of its heat to heat sanitary water. The heating condition is a higher temperature of heated water in the alternative source than the temperature of sanitary water in the heat storage. The heating takes place with the circulation of heated water from alternative source through pipe exchanger in the heat storage. Alternative sources can be solar collectors, wood biomass boiler or a fireplace. The control of flow pump of the alternative source requires the **placement of temperature probe of the alternative source** into the alternative source.

An **additional source** is the source of heating for which it is expected to be available, when there will be a need to heat sanitary water in the heat storage. The additional source is activated in the cases when the device is not operational since environmental parameters (air temperature or stored water temperature) is outside the operational range of the device or there is a need for quicker heating and works together with the device. Additional sources can be an oil / gas / pellets / wood biomass powered boiler, electric heater, etc. Activation of the additional source is controlled by the device controller.

The device controller automatically controls the operation of circulation pump of the external source in the case of use thereof (collectors, fireplace, wood biomass boiler...) or additional source (gas boiler, additional electric heater, wood pellet boiler...). For a proper operation, you must simply properly connect the circulation pump, temperature probe of the alternative source, and set the parameters in the device controller.

For a proper electrical connection of the attachments follow the instructions in the chapter about the electrical connection, and for the setting of the controller, the chapter on operation.



WARNING

Due to use of different materials on the pipe installation, all connections (cold water, hot water, circulation, heat exchanger) on the device must obligatorily be galvanically isolated, or the corrosion of connections within the heat storage may occur. We recommend galvanic separators from red alloy for each attachment, at least 2x pipe diameter in length.



WARNING

Water used for sanitary water heating through the installed heat exchanger in the hot sanitary water tank must comply with requirements of standard VDI 2035. The heating system must be filled with soft water, which contains anti-corrosive and anti-bacterial substances for prevention of corrosion. Before filling, the heating system must be cleaned of all impurities.

The heating system must be thoroughly drained of all air. Prevent the intrusion of air into the system, including diffusion air.

Maximal allowed content of individual substances in heated water and their influence on the heat exchanger are shown in the table below. The heated water which includes any substance in a concentration which causes corrosion (influence "-") in the heating system is forbidden. The heating water which contains two or more substances in a concentration, which may cause corrosion (influence "0") in the heating system is also forbidden.

TYPE OF SUBSTANCE	UNIT	CONCENTRATION	INFLUENCE ON HEAT EXCHANGER
Organic sediments	mg/L		0
Ammonia NH ₃	mg/L	< 2	+
		1 do 20	0
		> 20	-
Chloride	mg/L	< 300	+
		> 300	0
Allowed water hardness	°dH	5–10	
Electrical conductivity	µS/cm	< 10	0
		10–500	+
		> 500	-
Iron (Fe) separate	mg/L	< 0,2	+
		> 0,2	0
Free carbonic acid	mg/L	< 5	+
		5–20	0
		> 20	-
Manganese (Mn) separate	mg/L	< 0,1	+
		> 0,1	0
Nitrates (NO ₃) separate	mg/L	< 100	+
		> 100	0
pH value	mg/L	< 7,5	0
		7,5–9	+
		> 9	0
Oxygen	mg/L	< 2	+
		> 2	0
Hydrogen sulphide (H ₂ S)	mg/L	< 0,05	+
		> 0,05	-
HCO ₃ ⁻ / SO ₄ ²⁻	mg/L	> 1	+
		< 1	0
Hydrogencarbonate (HCO ₃ ⁻)	mg/L	< 70	0
		70–300	+
		> 300	0
Aluminium (Al) separate	mg/L	< 0,2	+
		> 0,2	0
Sulphates	mg/L	< 70	+
		70–300	0
		> 300	-
Sulphite(SO ₃)	mg/L	< 1	+
Chlorine (gas) (Cl ₂)	mg/L	< 1	+
		1–5	0
		> 5	-

Table: Influence of various aggressive substances in heating water onto the durability of hot sanitary water tank (+ = no influence, 0 = danger of corrosion, - = corrosion – use forbidden).



WARNING

The heating system must be filled with water of a hardness between 5 °dH and 10 °dH . Device defects due to unsuitable heating water hardness are not covered by warranty.



WARNING

Quality of potable water must comply with **Potable Water Regulation** (Official Gazette of the Republic of Slovenia, no. 19/04, 35/04, 26/06, 92/06, 25/09). This regulation complies with the European Council Directive 98/83/EC.



WARNING

For proper operation of active anti-corrosion protection, the hot sanitary water tank (boiler) must be filled with water, the conductivity of which is at least 200 µS.

Below, there are several possible connection schemes for external sanitary water heating sources.

- | | | | |
|---|--------------------------|----|-------------------------|
| 1 | Ball valve | 7 | Circulation pump |
| 2 | Pressure reduction valve | 8 | Device generator |
| 3 | Check valve | 9 | Boiler |
| 4 | Safety valve | 10 | Buffer tank |
| 5 | Expansion vessel | 11 | Solar energy collectors |
| 6 | Drain tap | dT | Differential thermostat |

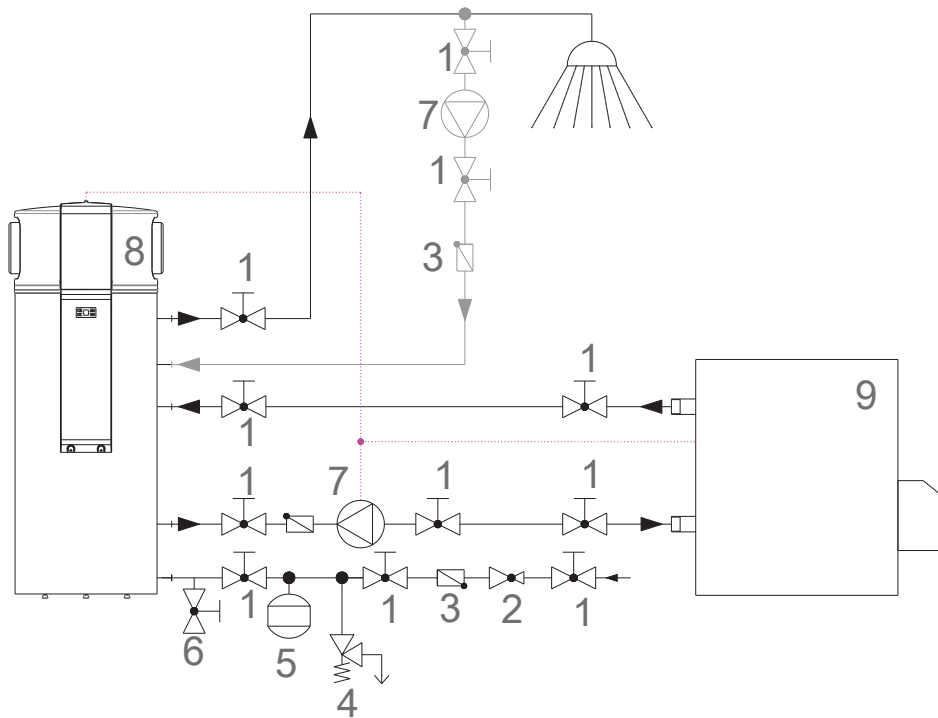

Figure 9: Heat pump combined with boiler.

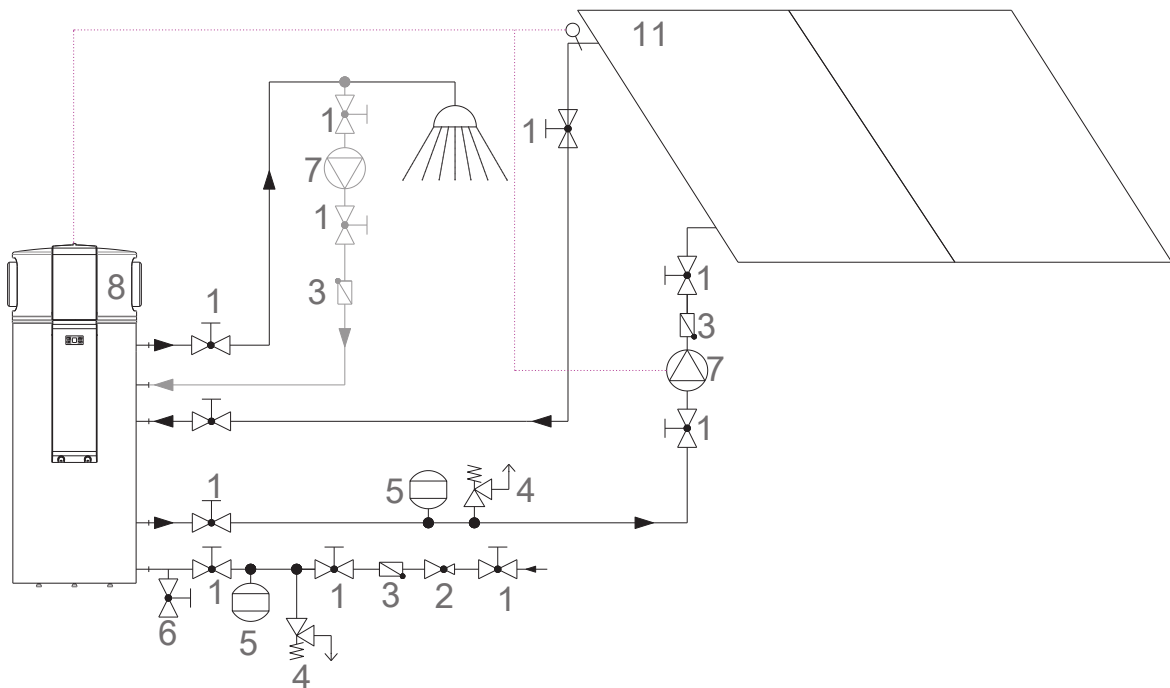

Figure 10: Heat pump combined with solar collectors.

6.7 Placement of External Controller Temperature Probe

In the case of use of a controller of additional source, attach temperature probe of the external controller into the appropriate canal on the right side of the device, under the black plastic cap, as marked on the image.

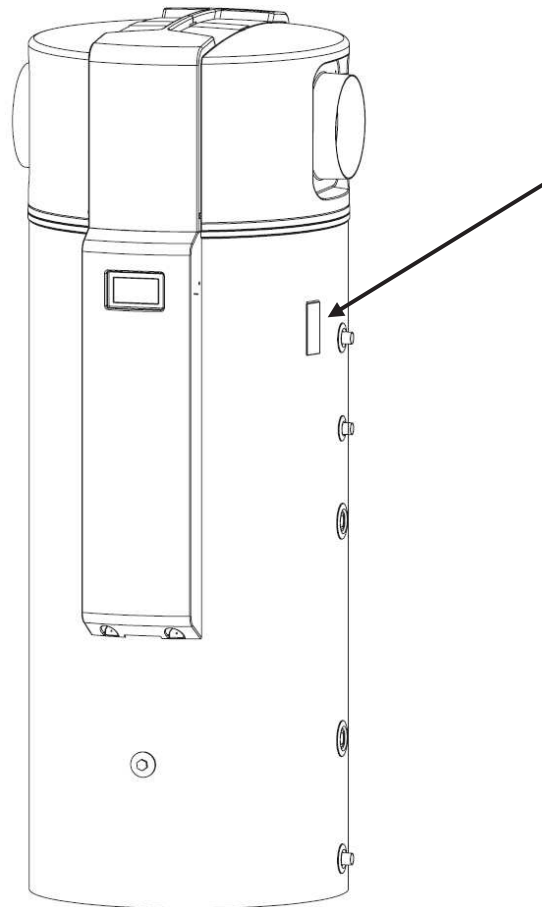

Figure 9: Temperature probe canal on the right side of the device



NOTE

To ensure a safe and efficient operation of the additional heat source for the preparation of sanitary water (boiler, solar collectors), the controller of the external source needs to be set to a limit of water heating of max 85 °C. It is recommended to set the temperature at 65 °C or less.

The highest permitted water temperature in the heat exchanger is 110 °C.

6.8 Parallel Connection of Several Devices

In case of a need for large quantities of hot water, you can install several devices in a parallel connection. For appropriate operation, the installation must comply with the instructions below.

Connection of Cold - Hot Water and Circulation

1	Ball valve	7	Circulation pump
2	Reduction valve	8	Reduction valve
3	Check valve	9	Device
4	Safety valve	A	Cold water
5	Expansion vessel	B	Hot water
6	Drain tap	C	Circulation

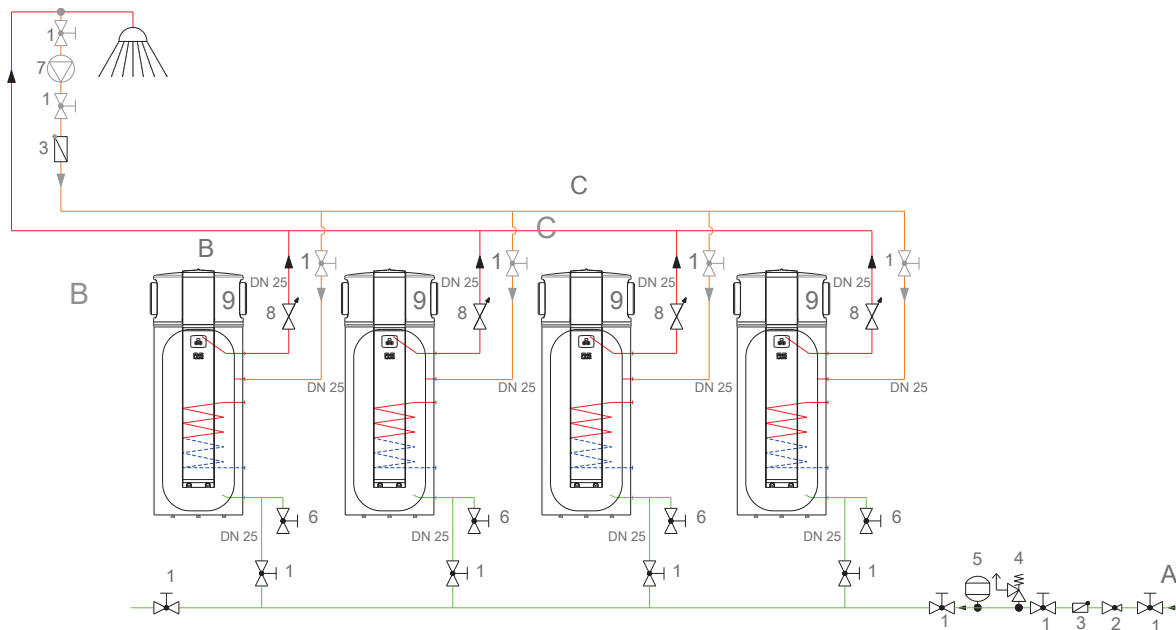

6.8.1 Connection to Boiler

1	Ball valve	6	Drain tap
2	Reduction valve	7	Circulation pump
3	Check valve	8	Reduction valve
4	Safety valve	9	Device
5	Expansion vessel	10	Boiler

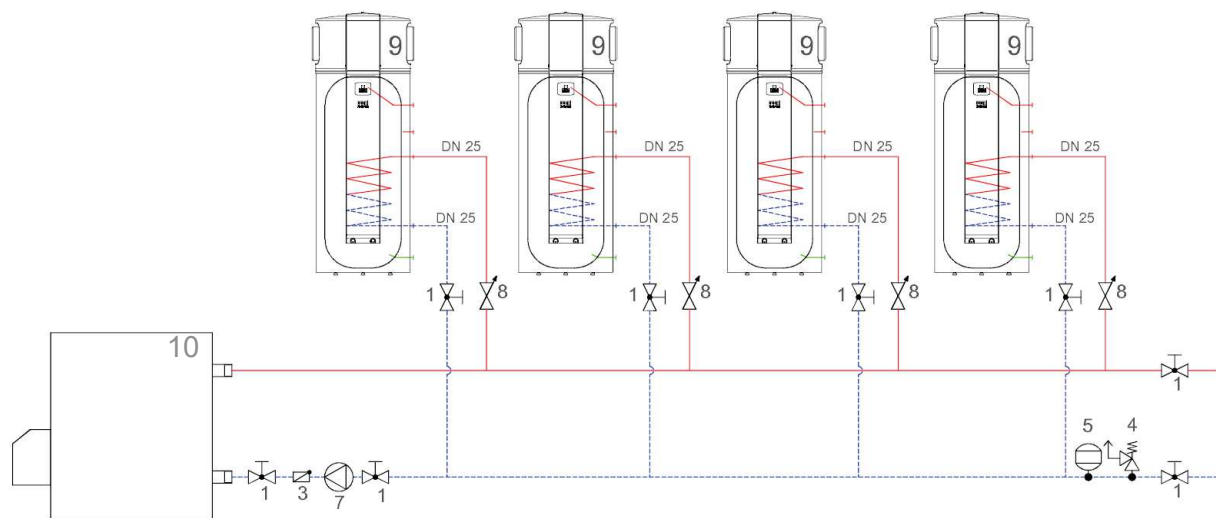

6.8.2 Air Canal Connection

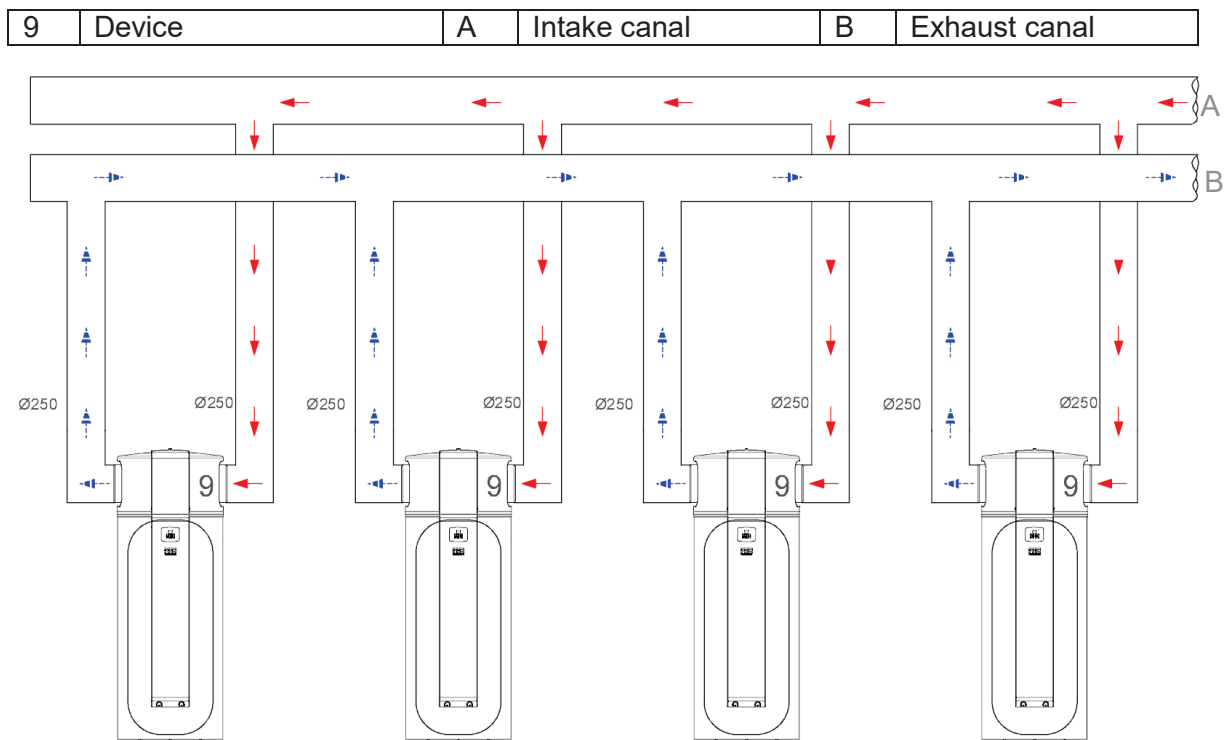

Table: Internal diameter of pipes depending on length of canals and number of devices.

Length of pipe	Number of devices									
	1	2	3	4	5	6	7	8	9	10
10 m	φ 150	φ 200	φ 250	φ 250	φ 300	φ 300	φ 350	φ 350	φ 350	φ 350
20 m	φ 200	φ 250	φ 300	φ 300	φ 350	φ 350	φ 400	φ 400	φ 450	φ 450
30 m	φ 200	φ 250	φ 300	φ 350	φ 350	φ 400	φ 400	φ 400	φ 450	φ 450

Largest allowed pressure drop on an individual device is 55 Pa.

6.9 Electric Connection

Electric connection of the supply cable, external signal, additional probe, and additional heater is done under the cover on the front of the device. To access electrical connections the front cover must be removed as shown below:

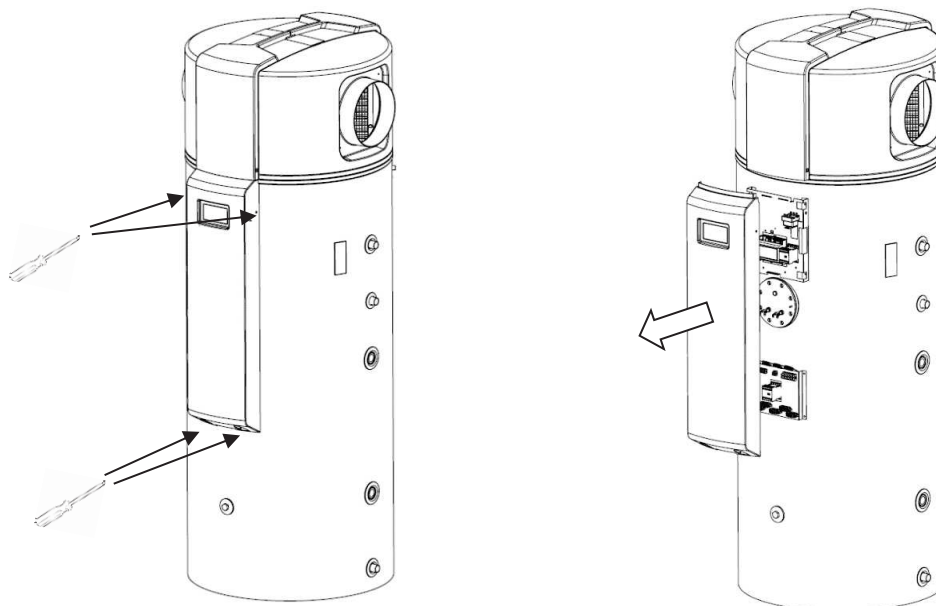

Figure 10: Front cover removal



WARNING

Connection of the device to the power grid must take place in accordance with standards for connection to electrical grids. The device must be connected to the electrical grid via a shutdown element, built into the electrical installation according to valid regulations. The shutdown element must separate all contacts under the conditions of overload category III.

All electrical connections are carried out on the bottom carrier, where electrical pins with cable release pins are prepared.

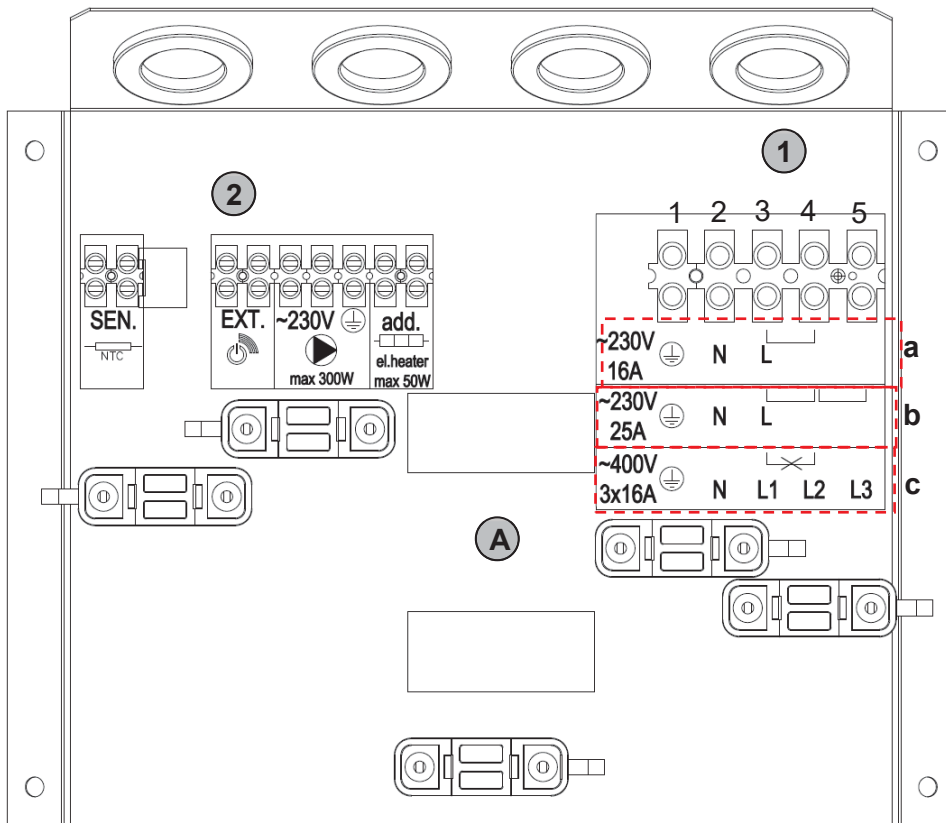

Figure 11: Connection pin carrier

6.9.1 Power Supply:

- ① Power supply is carried out via pins marked with 1. Three connections of power supply are possible:
 - a) Single-phase connection with maximal current load of 16 A is done on pins in the area **a**, using pins **N** and **L**.
 - b) Single-phase connection with maximal current load of 25 A is done on pins in the area **b**, using pins **N** and **L**.
 - c) Three-phase connection with maximal current load of 2x16 A is done on pins in the area **c**, using pins **N**, **L1**, **L2** and **L3**.

With all three connection types, the pin \ominus is used for earthing, and the pin **N** for a neutral lead. **1f** detailed connection is described below in points **a** and **b** while the **3f** connection is described in point **c**.

a. Single-phase connection with maximal current load of 16 A

This connection is used when single-phase power supply with 16 A fuses is available. In this connection type connect power supply phase to pin **3**. This is connected to pin **4** with a bridge (factory connection).

This connection enables the operation of device generator and the first installed electric heater (2 kW). The second heater is not active in such a case.
 Supply cable needs to have a circumsection of $3 \times 2,5 \text{ mm}^2$.
 Maximal total electrical power for this connection is 3,5 kW.

b. Single-phase connection with maximal current load of 25 A

This connection is used when single-phase power supply with 25 A fuses is available. In this connection type, connect power supply phase to pin 3. This is connected to pin 4 with a bridge (factory connection).

To connect the second electric heater (2 kW) it is necessary to **additionally** connect the bridge between connection pins 4 and 5.

This enables the operation of the device generator and both installed electric heaters (2 x 2 kW).

Supply cable needs to have a circumsection $3 \times 4 \text{ mm}^2$.

Maximal total electrical power for this connection is 5,5 kW.

c. Three-phase connection with maximal current load of 3 x 16 A

This connection is used when three-phase power supply with 3x16 A fuses is available. In this type of connection, every phase is connected to an individual pin (1, 2, 3, 4 and 5).

This enables the operation of the device generator and both installed electric heaters (2 x 2 kW).

Supply cable needs to have a circumsection $5 \times 1,5 \text{ mm}^2$.

Maximal total electrical power for this connection is 5,5 kW.



ATTENTION:

In three-phase connection, it is obligatory to **remove** the bridge which is factory placed and connecting pins 3 and 4.

6.9.2 Additional Heat Source Connection

- ② Left connection pin is intended for the connection of the circulation pump, external switch and heat probe of the external source.

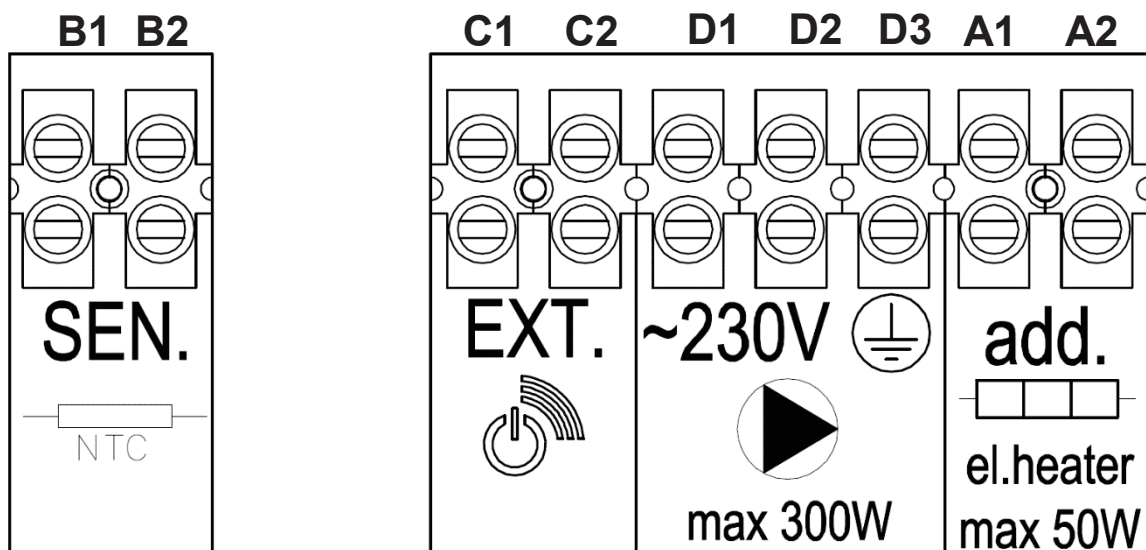

Temperature probe of the external heat source must be connected to pins with markings B1 and B2. To measure external heat source temperature (differential thermostat) use temperature probe of the NTC type (10K 1% BETA 3435 1%). Temperature probe power supply is 5 V.

External signal switch is used to switch on various device functions. Connect external switch on positions C1 and C2.



WARNING

Bring the tension of ~ 230 V on the pins of the external signal and circulation pump.

Circulation pump must be connected to the pins under the markings D1, D2 and D3. Connect the steady voltage of ~230 V to D1 and D2 and the neutral lead, and use D3 for the earthing lead. Maximal load of the circulation pump is 300 W.



WARNING

Connection pins of the temperature probe for the external heat source are under 5 V tension.

6.9.3 Connection of Additional Electric Heater Activation (option)



The carrier (figure 11) allows you to use location a to install an additional connector for the activation and supply of an additional electric heater, installed on the G connection (figure in chapter 5) at the bottom of the hot sanitary water tank. The electric heater is available from the manufacturer as an accessory.

Control pins of the connector (A1, A2) should be connected to the pins under the mark **3** (figure 13) on the pin carrier. Then connect the electric heater to the connector, which you must ensure an external power supply for.

7. Device Startup

7.1 Filling Device With Water

After a professional attachment of the heat pump onto the plumbing, the system needs to be filled with water and air thoroughly removed from it. This is done by opening all faucets in the apartment. When water flows without interruptions from all faucets, there is no more air in the system.



WARNING

The heat pump must never function without water in the hot water tank.

7.2 Controls Before Startup

Before device start-up, the following controls have to be carried out:

- ▶ Hot water tank must be filled with water and air thoroughly removed from it.
- ▶ All hydraulic connections must be tightly sealed.
- ▶ Suitable expansion vessel and appropriate safety valve must be built in.
- ▶ All safety elements must be operationa.

7.3 Device Startup

After the first connection, onto the power grid, the device is not yet operational. The device is factory set to the programme **OFF** and a suitable operation programme has to be picked for water heating (*chapter 8.3.3*). The controller display shows clock setting (*chapter 8.3.9*). Should the clock be factory set, the display shows the basic temperature of sanitary water after activation (*chapter 8.1.1*).

8. Controller

The interface of device controller OPTITRONIC 2 consists of a colour LCD display and four function keys for operation.

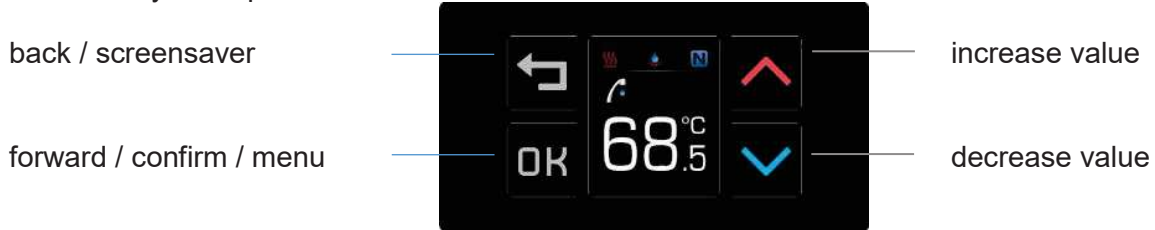

8.1 Basic Window

8.1.1 Sanitary Water Temperature

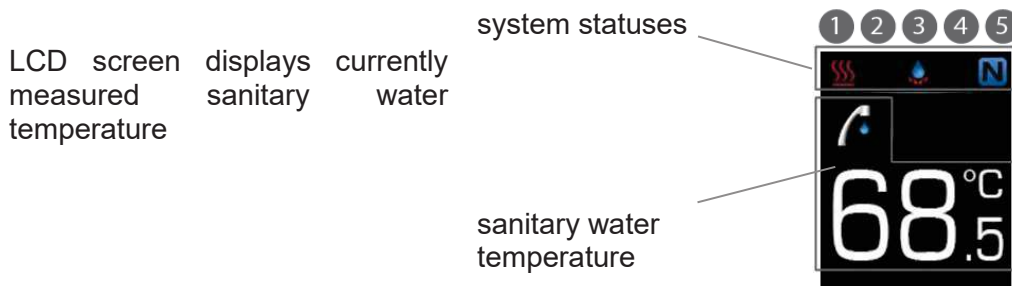



8.1.2 System statuses

Display current device operation. The statuses show the active operation programme, functioning of individual system components and potential errors and warnings.



Legend of system statuses:

1	Operation of compressor and backup source	2	Alternative / additional source state
	Device generator heating sanitary water		Internal electric heater active
	Backup source programme active		External source active
	Device on standby		Internal heater and external source active
	Device in startup mode		
3	Active programme	4	Warnings and defects
	Anti-freeze programme active		External input influencing operation
	Defrosting programme active		Warning
	Quick water heating programme active		Error
	Overheating - anti-legionella programme active		
5	Operation mode		
	Holiday programme active		COMFORT PLUS programme active
	NORMAL programme active		ALTERNATIVE OPERATION programme active
	ECO programme active		OFF programme active
	COMFORT programme active		PHOTOVOLTAICS (PV) programme active

8.1.3 Setting of Desired Temperature of Sanitary Water

In the basic window, by pressing  or  we begin setting the desired temperature of sanitary water.



Currently set desired temperature is displayed. By pressing the key  or  the value is increased or decreased. To confirm change of desired sanitary water temperature, press **OK**.

8.2 Screensavers



When we aren't using the controller, the screen displays screensavers. Those are meant for quick display of important heating system information. Presence of individual screensavers depends on the activities and individual functions, type of heat pump and presence of module OPTITRONIC 2.

Enter into screensaver window with .

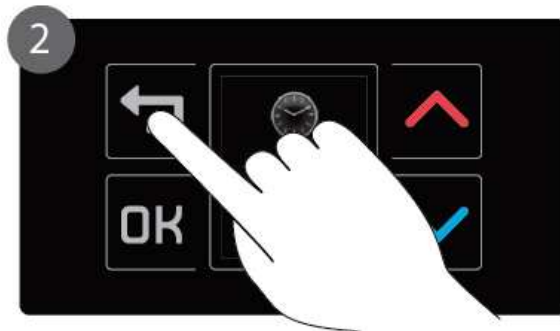

Move between windows with the key .

Exit from screensaver view with the key **OK**.

8.2.1 All screensavers



Display of device time



Display of external source temperature



Display of incoming air temperature



Display of system warnings
See chapter 10.1.



Display of system errors
See chapter 10.2

Additional screensavers for built in OPTITRONIC 2 - WEB module (option):



Display of time and date. Time and date are automatically synchronised with local time via the Home Cloud server.



Display of connection status with the cloud (server Home Cloud).



Display of connection status for local network connection.

8.3 Menu

In the basic window, by pressing **OK**, we enter into the menu. The menu contains settings and programmes of device operation.

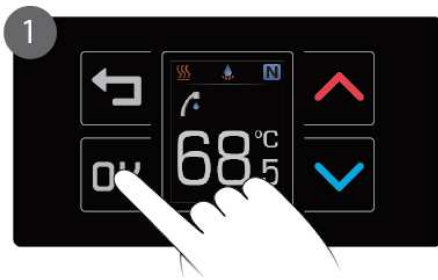

Enter menu with **OK** key.



Move between settings with keys **▲** or **▼**.

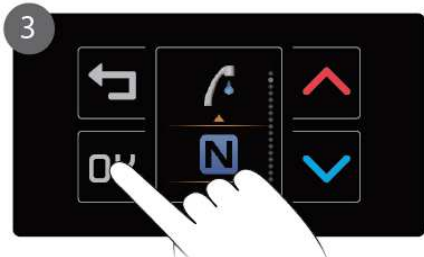

Use key **OK** to enter desired setting menu.



Use keys **▲** or **▼** to select desired setting.

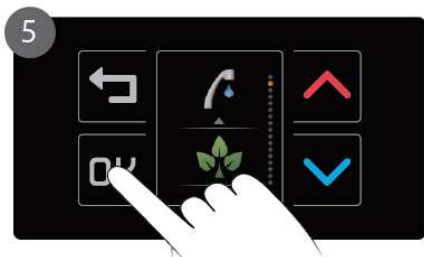

Use key **OK** to confirm new setting. If you wish to cancel the change, use key **↶** to return to menu.



Orange indicators indicate current selection on the controller.

8.3.1 Error Acknowledgement



In the case of one or several errors on the device, the menu displays a new setting "Error Acknowledgement". After acknowledging an error the device will restart and check if the cause of error has been removed. If the error has been removed, the setting "Error Acknowledgement" is not visible in the menu any more.



Enter "Error Acknowledgement" setting with the key **OK**.



Use key **OK** to acknowledge errors. The menu shows up again.

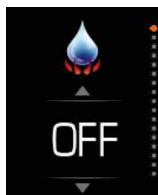

8.3.2 Quick Water Heating



The programme for quick heating is intended for one time quick water heating with the device and chosen additional heat source at the same time (*chapter 9.3.1*). After achieving a temperature, the quick heating programme switches off and changes to previous operation mode. The programme is started by selecting the setting »**START**«.

8.3.3 Basic Operation Programme



Using direction keys  and  select between basic device operation programmes. Confirm selection with the key **OK**.



NOTE

Additional operation programmes such as "Quick water heating" (*chapter 8.3.2*), "Daily schedule" (*chapter 8.3.6*), "Vacation" (*chapter 8.3.8*), etc. have priority over basic operation programmes.



Operation programme NORMAL



Operation programme COMFORT PLUS



Operation programme ECO



Operation programme OFF





Operation programme COMFORT



Operation programme ALTERNATIVE OPERATION

8.3.4 Temperature Deviation ECO





In the ECO operation programme, the device heats water to desired temperature while considering a negative deviation. The desired deviation is chosen with keys  and . Setting is confirmed with the key **OK**.

Setting range: 0 °C – 15 °C.
Setting step: 0,5 °C.

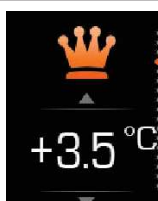
8.3.5 Temperature Deviation COMFORT



In the COMFORT operation programme, the device heats water to desired temperature while considering a positive deviation. The desired deviation is chosen with keys  and . Setting is confirmed with the key **OK**.

Setting range: 0 °C – 15 °C.
Setting step: 0,5 °C.

8.3.6 Daily Schedule



A change of operation programme can be automatic by setting up a daily schedule. Every daily schedule may have two time intervals. Every interval has a set starting time, ending time, and programme of operation. In the time outside the set intervals of the schedule, the device operates according to basic programme.



NOTE

To set and operate weekly schedules, the device needs to be equipped with the OPTITRONIC 2 – WEB module (option).

Move between schedule setup windows with the key **OK**.



1 Enter schedule setting with the key **OK**.



2 Turn schedule »ON« or »OFF«.



3 Set starting time of schedule interval.



4 Set ending time of schedule interval.



5 Set operation programme in the time of interval.

8.3.6.1 Weekly Schedule (option)



The schedule may be set for every day in the week separately. Every daily schedule can have up to three time intervals. Every interval has a set starting time, ending time, and programme of operation. In the time outside the set intervals of the schedule, the device operates according to the basic programme.



NOTE

To set and operate weekly schedules, the device needs to be equipped with the OPTITRONIC 2 – WEB module (option).

Move between schedule setup windows with the key **OK**.



1 Enter schedule setting with the key **OK**.



2 Pick the day of the week (1-Monday 7-Sunday).



3 Turn schedule »ON« or »OFF«.

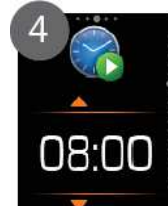

4 Set starting time of schedule interval.

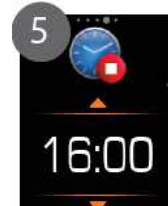

5 Set ending time of schedule interval.

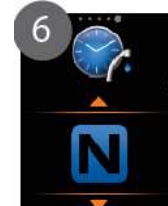

6 Set operation programme in the time of interval.

8.3.7 Ventilation Schedule



The devices with guided air, along with sanitary water heating, also enable cooling and ventilation of rooms. Ventilation functions according to set intervals of a ventilation schedule with set start and end times.



NOTE

To set and operate weekly ventilation schedules, the device needs to be equipped with the OPTITRONIC 2 – WEB module (option).

Move between schedule setup windows with the key **00**.



Enter schedule setting with the key **OK**.



Turn schedule **»ON«** or **»OFF«**.



Set starting time of schedule interval.



Set ending time of schedule interval.

8.3.8 Vacation

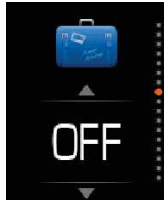

The vacation programme allows us to shut down the device for a specific number of days when we know we will not require hot water. In this period, no programme is active, even if it's set on a schedule. When the set time interval passes, the device automatically switches back to basic operation programme.



NOTE

In the case that the vacation programme was activated and in operation at least for 1 day, the overheating programme will activate after the ended vacation programme (*chapter 8.3.11*)

Move between schedule setup windows with the key **OK**.



Enter vacation setting with the key **OK**.



Turn vacation programme **»ON«** or **»OFF«**.



Set number of days (duration) of vacation programme.

8.3.9 Time



Manual setting of time on the device.



NOTE

In case that your device has the OPTITRONIC 2 - WEB module (option) installed and is connected to the server Home Cloud, the time and date of the device are automatically synchronised with the server Home Cloud.

8.3.10 Backup Source



Manual activation and deactivation of the programme Backup Source (*chapter 9.1.3*)

8.3.11 Overheating Programme - Anti-legionella

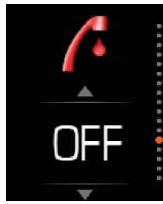

Programme heats water to 65 °C, to remove potential legionella bacteria. Activation can be automatic or manual.



NOTE

Factory preset overheating is automatic every 14 days. We advise against overheating too often, as energy consumption during overheating is 1/3 higher than during normal operation.

8.3.12 Automatic Quick Water Heating

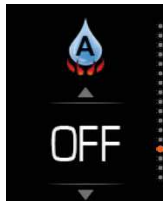

Programme "Quick water heating" (*chapter 9.3.1*) can be triggered automatically when water temperature falls below the set value.

Move between setup windows with the key **OK**.



Enter setting with the key **OK**.



Turn programme »**ON**« or »**OFF**«...



Set temperature at which the "Quick Water Heating" programme activates.

8.3.13 Screen Brightness



Screen brightness settings.

Parameters from lowest to full brightness:



8.3.14 System Information



The devices with guided air, along with sanitary water heating, also enable cooling and ventilation of rooms. Ventilation functions according to set intervals of a ventilation schedule with set start and end times.

Move between setup windows with the key **OK**.



Enter setting with the key **OK**.



Data about graphic panel OPTITRONIC 2.



Data about main controller OPTITRONIC 2.



Data about module OPTITRONIC 2 - WEB (option).



8.3.15 Advanced Installation Settings



Menu allows access to advanced controller settings by entering a 4 digit security PIN code.

PIN koda: 1234



Use keys  and  to select number and the key  to move to the next field.

8.3.15.1 Automatic Overheating Programme - Anti-legionella



Overheating programme (*chapter 8.3.11*) can be set to work on schedule. Factory setting is a repetition of the programme every 14 days. (Settings allow for periods of 1 - 99 days).

If we do not wish to use automatic overheating, the period is set to OFF.



WARNING

The overheating period must obligatorily be set in regards to the national regulation requirement for safe preparation of hot sanitary water.

8.3.15.2 Additional Source Selection



Additional source function (*chapter 9.1.2*) allows the activation of one or a combination of heat sources. (Selection depends on heat pump type and presence of other heat sources in the heating system):



Internal electric heater.



Internal electric heater and external source.



External source.



Deactivation of additional source function.

8.3.15.3 External Input



The device may be set to change operation programme upon detecting an external input signal.

The external input signal may be triggered by a switch (key) or external device signal (furnace, solar photovoltaic panels, electric counter, etc.).

Several operation programmes are possible:



NORMAL: Switch to programme NORMAL



OFF: Remote switch to programme OFF during longer absence from home (device is not in use for a prolonged time).



ECO: Switch to programme ECO when power tariff is higher to reduce heating costs.



Quick water heating:
Remote programme activation.



COMFORT: Switch to programme COMFORT when power tariff is lower to increase efficiency of operation.



PHOTOVOLTAICS: Solar photovoltaic system.



COMFORT Plus: Switch to programme COMFORT Plus, when power from solar panels is available.



Backup source: Activation of backup source programme.



Function input 1



Function input 2



Function input 3

8.3.15.4 Standby Setup

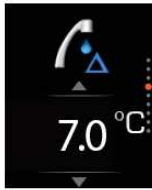

When water reaches desired temperature, the heating switches off and enters standby mode until water temperature doesn't drop for the standby level difference.

Factory setting for standby difference 7 °C.
Setting area: AUTO or 2 °C – 10 °C.
Setting step: 0,1 °C..

Example: Water heating will deactivate after reaching the desired temperature 55 °C. Heating will reactivate once temperature drops for the standby difference 7 °C, thus to 48 °C.

Dynamic standby:

In case of setting the standby temperature to AUTO, the standby temperature changes in regards to the set desired water temperature. If the temperature set is 40 °C, standby temperature difference is 5 °C, while in the case of water temperature 55 °C and more, standby equals 10°C. Between temperatures 40 °C and 55 °C the standby temperature difference is calculated in a linear way between 5 and 10 °C.

Static standby:

Other standby settings are static and are the same for all water temperatures. The minimal temperature difference is thus 2 °C, and the maximal 10 °C. Factory standby difference is set to 7 °C.

8.3.15.5 Temperature Settings for PHOTOVOLTAICS Programme

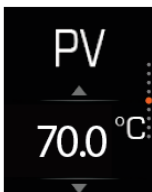

Device in the programme PHOTOVOLTAICS - PV (solar photovoltaic system) (chapter 9.3.4) heats sanitary water to PV temperature setting.

The factory setting is 70 °C.
Setting range: 55 °C – 85 °C.
Setting step: 0,5 °C..

8.3.15.6 Standby in PHOTOVOLTAICS Programme



When the temperature of sanitary water in the programme PV (chapter 8.3.4) drops under the set desired temperature for the programme PV for the temperature deviation value («Standby in PHOTOVOLTAICS Programme»), the device resumes heating the sanitary water.

Factory temperature deviation setting is 3 °C
Setting range: 1 °C – 20 °C.
Setting step: 0,1 °C

8.3.15.7 Setting of Maximal External Source Temperature

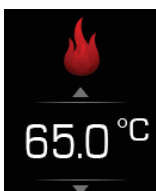

In the case of external source use, maximal temperature is set, up to which the external source may heat water. The standby temperature in this mode is set to a fixed value of 10 °C.

Factory temperature setting is 60°C.
Setting range: 20 °C – 85 °C.
Setting step:5 °C



NOTE

Maximal external source temperature setting is only used when a programme of alternative operation is active (*chapter 9.2.2*).

8.3.15.8 Setting of External Source Use Priority



The setting defines the operation of device generator and external source regime (*chapter 9.2*)



Priority external source



Priority device generator

9. Device Operation Setting

9.1 Basic Operation

Compressor is used for primary water heating. The compressor operates in a limited temperature area of entering air (from -7 °C to 35 °C). Outside this area, the controller shuts down compressor operation for safety reasons. The compressor may heat water to a maximal temperature of 65 °C.

9.1.1 Basic Operation Programmes



NORMAL: For heating water to desired temperature (*chapter 8.1.3*), the device uses the primary heat source (compressor) whenever it is possible. When the primary heat source, due to conditions (e.g. entering air temperature) cannot provide enough power, the device adds the additional power source (e.g. electric heater) to aid in water heating.



ECO: Water is heated to desired temperature (*chapter 8.1.3*), with a considered negative deviation ECO. The final water temperature is lower than in the NORMAL mode. ECO deviation setting can be found in the user menu (*chapter 8.3.4*).



COMFORT: Water is heated to desired temperature (*chapter 8.1.3*) with a considered positive deviation COMFORT. The final water temperature is higher than in the NORMAL mode. COMFORT deviation setting can be found in the user menu (*chapter 8.3.5*)





OFF: The device is off.

9.1.2 Additional Source

When the entering air temperature is outside the work area of the compressor of the device generator, the water can be heated by the internal electric heater.



NOTE

SETTING: in the menu  ADDITIONAL SOURCE SELECTION (*chapter 8.3.15.2*) the internal electric heater is selected .

9.1.3 Backup Source

In case of a compressor defect, the device automatically switches to backup operation. It heats water with the internal electric heater to a temperature, set with the basic programme. Thus, the backup operation is ensured until authorised service arrives and removes the defect.



NOTE

Backup source can also be activated and deactivated manually (*chapter 8.3.10*).



9.2 Operation With External Source

External heat source is located outside the device (e.g. oil / gas / pellet / wood furnace, solar collectors, fireplace, external electric heater, etc.).

Additional heat source can heat water **together with the generator** of the device and performs the functions of an **additional source** or heats water independently, **instead of the generator** of the device, in the function of an **alternative source**.



NOTE

SETTING: in the menu  ADDITIONAL SOURCE SELECTION (*chapter 8.3.15.2*) select  »external source« or  »electric heater + external source«.

Controller enables two modes of operation:

- Water is heated by device and external source
- Water is only heated by external source - alternative operation

9.2.1 Water Heated by Device and External Source

Water heating to temperature, set with the basic programme, takes place with the device compressor and external source.

In regards to type of external source, we divide between two operation priorities:

- Priority device generator
- Priority external source



9.2.1.1 Priority Device Generator

This setting is used when an external heat source is available, which the device may activate via electric signal (oil / gas / pellet / wood furnace, external electric heater). External source is in the function of **additional source**.

The machine generator is used to heat water. When the temperature of entry air is outside the work range of the compressor, the device signals the activation of the external source, which heats water to the temperature, set with the basic programme.



NOTE

SETTING: in the menu  EXTERNAL SOURCE OPERATION PRIORITY (*chapter 8.3.15.8*) select parameter  »Priority device generator«.



9.2.1.2 Priority External Source

This setting is used when an external heat source is available which the device cannot influence and which operates independently (firewood furnace, fireplace, solar collectors). External source is in the function of an **alternative source**.

Basically, the water is heated by the device generator. When the temperature of external source is higher than the water temperature in the water tank (*chapter 9.2.3*), the device switches off the compressor, starts the circulation pump of the external source and automatically activates the alternative operation mode (*chapter 9.2.2*). Water heating takes place only with external source to the maximal external source temperature (*chapter 8.3.15.7*). If the external source temperature drops under the set limit (*chapter 9.2.3*), the device switches off the circulation pump of the external source and automatically switches off the alternative mode. Water heating continues with the compressor.



NOTE

SETTING: in the menu  EXTERNAL SOURCE OPERATION PRIORITY (*chapter 8.3.15.8*) select parameter  »Priority external source«..

9.2.2 Water Only Heated by External Source - Alternative Operation

Water is heated exclusively by external source. This is a special operation mode, active when water heating is not done with the device compressor. Activation of this operation mode can be automatic when the setting »Priority external source (chapter 9.2.1.2) is active, or manual, when selecting it in the basic operation menu (chapter 8.3.3).



NOTE

MANUAL ACTIVATION: in the menu BASIC OPERATION PROGRAMME (chapter 8.3.3) select programme »Alternative Operation«.



NOTE

When manually activating alternative operation mode via basic operation menu (chapter 8.3.3), the device will not use the compressor to heat water in normal programmes. In case that the external source temperature drops below the value of the temperature of water in the hot water tank (chapter 9.2.3), water heating will be interrupted!



NOTE

Generator compressor will work together with alternative source in the case of the activation of additional operation programmes »Quick water heating« (chapter 9.3.1) and the programme »COMFORT Plus« (chapter 9.3.2)

External source heats water to set maximal temperature of the external source.



OPOMBA

NASTAVITEV: v meniju MAKSIMALNA TEMPERATURA ZUNANJEGA VIRA (chapter 8.3.15.7) nastavite temperaturo od 20 °C do 85 °C.

There are two priorities of operation in regards to external source type:

- Priority device generator
- Priority external source

9.2.2.1 Priority Device Generator

This setting is used when an external heat source is available, which the device may activate via electric signal (oil / gas / pellet / wood furnace, external electric heater). External source is in the function of **alternative source**.

Device signals the external source to activate and it heats water to temperature, set with the "Maximal external source temperature" setting. If the external source is not available after activation, the device reports error E07 (chapter 9.2.3).



NOTE

SETTING: in the menu EXTERNAL SOURCE OPERATION PRIORITY (chapter 8.3.15.8) select parameter »Priority device generator«



NOTE

When manually activating alternative operation mode via basic operation menu (chapter 8.3.3), the device will not use the compressor to heat water in normal programmes. In case that the external source temperature drops below the value of the temperature of water in the hot water tank (chapter 9.2.3), water heating will be interrupted!

9.2.2.2 Priority External Source

This setting is used when an external heat source is available which the device cannot influence and which operates independently (firewood furnace, fireplace, solar collectors). External source is in the function of an **alternative source**.

When external source has sufficient heat (*chapter 9.2.3*), the device activates the circulation pump of the external source and heating with external source begins.





NOTE

SETTING: in the menu  EXTERNAL SOURCE OPERATION PRIORITY (*chapter 8.3.15.8*) select parameter  »Priority external source«.



NOTE

When manually activating  alternative operation mode via basic operation menu  (*chapter 8.3.3*), the device will not use the compressor to heat water in normal programmes. In case that the external source temperature drops below the value of the temperature of water in the hot water tank (*chapter 9.2.3*), water heating will be interrupted!

9.2.3 Setting Availability of External Source

The device checks conditions which define when the external source is available or has enough heat with two methods, depending on control of the external heat source:

External heat source which can be activated via electric signal (oil/ gas / pellet furnace, external electric heater):

The active mode of operation is "Priority device generator" (*chapter 9.2.1.1*), (*chapter 9.2.2.1*). When a need for external source appears, the device activates it with an electrical signal (while activating the circulation pump of the external source). Checking of the functioning of external source is carried out by comparing the external source temperature to the sanitary water tank temperature. When the temperature of external source is at least 5°C higher than the temperature of the sanitary water tank, the external source is available and used for water heating. If after *n* minutes from activation, the temperature of external source is not higher than 5°C, the external source activation electrical signal switches off for *n* minutes, then the activation procedure is repeated. If after three consecutive tries the activation of the external source is unsuccessful, the device reports error E07, which must be manually acknowledged (*chapter 8.3.1*). If alternative operation is manually activated (*chapter 9.2.2*) the alternative operation will be interrupted and the water heating will be taken over by the compressor or backup source.

External heat source which the device cannot influence and which operates independently (wood furnace, fireplace, solar collectors):



The active mode of operation is »Priority external source« (*chapter 9.2.1.2*) (*chapter 9.2.2.2*). In this operation mode, the device regularly checks the external source temperature. When the external source temperature is at least 10°C higher than the temperature in the sanitary water tank, the priority source of heating is the external source (the external source circulation pump is activated). When the temperature difference falls below 5°C, the external source ceases to be used for water heating. If alternative operation is manually activated (*chapter 9.2.2*) the alternative operation will be interrupted and the water heating will be taken over by the compressor or backup source.

9.3 Additional Operation Programmes



9.3.1 Quick Water Heating

The quick water heating programme  is intended for quick water heating with the device generator and selected additional source (*chapter 8.3.15.2*) at the same time. After reaching







the set temperature, the quick heating programme turns off and switches back to previously set operation mode.

Quick water heating programme may be stated manually  (*chapter 8.3.2*), automatically  (*chapter 8.3.12*) or via external input  (*chapter 8.3.15.3*).





Operation differs in regards to the set additional source (*chapter 8.3.15.2*):

-  Internal electric heater or **OFF** setting:
Water is heated by generator of the device and internal electric heater at the same time.
-  External source:
Water is heated by generator of the device and external source (if available - (*chapter 9.2.3*)).
-  Internal electric heater + external source:
Water is heated by generator of the device, internal electric heater and external source (if available - (*chapter 9.2.3*))

The temperature to which the water is being heated by the programme of quick heating depends on the programme in which the device operates:

-    Basic operation programmes:
Water is heated to temperature, defined by programme  COMFORT.
-  Alternative operation programme:
Water is heated to temperature, set in the menu  MAXIMAL EXTERNAL SOURCE TEMPERATURE (*chapter 8.3.15.7*).

9.3.2 COMFORT Plus

In the programme COMFORT Plus , the water is heated to desired temperature with consideration of positive deviation COMFORT. All available sources are used for heating ( device generator,  internal electric heater and  external source). Deviation setting COMFORT can be found in the user menu (*chapter 8.3.5*). The programme offers the quickest possible sanitary water heating, regardless of the cost of heating.

The programme COMFORT Plus can be activated manually (*chapter 8.3.3*), by schedule (*chapter 8.3.6*) or via external input  (*chapter 8.3.15.3*).



9.3.3 Anti-freeze Programme

The anti-freeze programme  is activated automatically and ensures that, in the case of a compressor defect, the system does not freeze. The factory setting is 35 °C.

The water heating programme uses heat from the selected additional source (*chapter 8.3.15.2*)





NOTE

If  additional source is not selected (*chapter 8.3.15.2*), or external source is not available (*chapter 9.2.3*), the programme will activate  internal electric heater.

9.3.4 PHOTOVOLTAICS

The programme photovoltaics **PV** (PV) is a programme of device operation which heats water with excess electrical power, obtained through a solar photovoltaic system. The programme **PV** activates when the device receives a PV signal via external input  (*chapter 8.3.15.3*).

When the PV signal is present,  the device generator heats water to maximal work margin of the compressor temperature (65°C), and from there on to the set temperature of the programme photovoltaics (*chapter 8.3.15.5*) water is heated by the  internal electrical heater. If alternative operation mode is active (*chapter 9.2.2*), the external source will be used for heating when it is available (*chapter 9.2.3*).



NOTE

SETTING: In the menu  EXTERNAL INPUT (*chapter 8.3.15.3*) select parameter »PHOTOVOLTAICS (PV)« .

10. Errors and Warnings

10.1 Warnings



Warnings on the screen of the controller are shown with a yellow triangle and codes W01-W07. Codes have following meanings:

WARNING W01 - Entry Air Temperature Too Low

If the entry air temperature drops under minimal air temperature (-7 °C), the device shuts down. A 30 minute activation block is triggered. After 30 minutes the fan switches on, then the air intake temperature is checked. If it is 3 °C above minimal air temperature, the device reactivates.

While the block is triggered, water is heated to Anti-freeze temperature setting (35 °C *chapter 9.3.3*) by the additional heat source, if one is selected (*chapter 8.3.15.2*), or the backup source (*chapter 9.1.3*). The warning is shown while the activation block is triggered.

To remove the error, the area where the device is installed must be ventilated, so that warmer air may enter the device. Should warmer air not be available, it is recommended to manually activate the backup source (*chapter 8.3.10*), or alternative mode (*chapter 8.3.3*), if an external source is connected to the system.

WARNING W02 - Entry Air Temperature Too High

If the entry air temperature is above the maxima air temperature (35 °C), the compressor shuts down. A 30 minute activation block is triggered. After 30 minutes the fan switches on, then the air intake temperature is checked. If it is 3 °C under the maximal air temperature, the device reactivates.

While the block is triggered, water is heated to Anti-freeze temperature setting (35 °C *chapter 9.3.3*) by the additional heat source, if one is selected (*chapter 8.3.15.2*), or the backup source (*chapter 9.1.3*). The warning is shown while the activation block is triggered.

To remove the error, the area where the device is installed must be ventilated, so that cooler air may enter the device. Should cooler air not be available, it is recommended to manually activate the backup source (*chapter 8.3.10*), or alternative mode (*chapter 8.3.3*), if an external source is connected to the system.

WARNING W03 – High Pressure

In the case of pressure in the cooling system of the generator being too high, the controller shuts down the device operation. After 5 minutes, the device is reactivated. If, after reactivation, the pressure is still too high, the device shuts down once again and displays the warning. Should the warning appear 3 times within 1 hour, the display shows error E05. See description of error E05 (*chapter 10.2*). To remove error, first check if there is enough water in the hopper. Should the warning still be displayed with enough water present, service has to be contacted.

WARNING W04 – Evaporator Temperature Too Low

If the temperature probe on the evaporator detects that the temperature is too low, the controller switches off the device and reports WARNING W04. The device is blocked for 30 minutes,

While the block is triggered, water is heated to Anti-freeze temperature setting (35 °C *chapter 9.3.3*) by the additional heat source, if one is selected (*chapter 8.3.15.2*), or the backup source (*chapter 9.1.3*). The warning is shown while the activation block is triggered.

The warning appears in the case of the use of air canals and set low speed of the fan (*chapter 8.3.15.8*), or in the case of air canal use and low entering air temperature.

To remove error, check fan speed (*chapter 8.3.15.8*) or ensure higher entering air temperature. Should warmer air not be available, it is recommended to manually activate the backup source (*chapter 8.3.10*), or alternative mode (*chapter 8.3.3*), if an external source is connected to the system.

WARNING W05 – Evaporator Temperature Too High

If the temperature probe on the evaporator detects that the temperature is too high, the controller switches off the device and reports WARNING W05. The device is blocked for 30 minutes.

While the block is triggered, water is heated to Anti-freeze temperature setting (35 °C *chapter 9.3.3*) by the additional heat source, if one is selected (*chapter 8.3.15.2*), or the backup source (*chapter 9.1.3*). The warning is shown while the activation block is triggered.

To remove the error, the area where the device is installed must be ventilated, so that cooler air may enter the device. Should error not be removed, service has to be called, and manual activation of the backup source (*chapter 8.3.10*), or alternative mode (*chapter 8.3.3*), if an external source is connected to the system, is required.

WARNING W07 – External Source Temperature Too High

If external source temperature exceeds maximal permitted temperature (*chapter 8.3.15.7*), the use of external source ceases. For the reactivation of external source use, the temperature must drop for 5°C. Device operates according to the set programme without using the external source. If manual alternative operation is active (*chapter 8.3.3*) sanitary water heating is interrupted until external source is once again available.

10.2 Errors



Errors are shown on the controller display with a red triangle and codes E01-E09. Codes have the following meanings:

Error E01 – Water Temperature Probe Error

Should there be a water temperature probe error, the device shuts down, and the additional chosen source or internal electric heater are also inactive. Only ventilation operates in the case that it is set to. Service has to be called to remove the error.

Error E02 – External Source Probe Error

Should there be an error on the external source temperature probe, the device continues to operate, but operation with external source is deactivated (*chapter 9.2*) To remove the error, one must first check if the installation of the probe was carried out compliant with the installation and instruction manual (Installation of Temperature Probe for External Source). IF the installation was carried out properly, probe operation has to be checked and, if required, service called. Use of external source is not possible until error is removed.

Error E03 – Entering Air Temperature Probe Error

Should there be an error on the entry air temperature probe, the device continues to operate (using the evaporator temperature). Should the error be displayed and device not be operational due to the air temperature being too low, it is recommended to manually activate the backup source (*chapter 8.3.10*) or alternative mode (*chapter 8.3.3*), if an external source is connected to the system. Service has to be called to remove the error.

Error E04 – Evaporator Probe Error

Should there be an error on the evaporator temperature probe, the device continues to operate, but only to a minimal air temperature difference of 10 °C. Should the error be displayed and device not be operational due to the air temperature being too low, it is recommended to manually activate the backup source (*chapter 8.3.10*), or alternative mode (*chapter 8.3.3*), if an external source is connected to the system. If, along with Error E04, Error E03 also appears,

water is heated to Anti-freeze temperature setting (35 °C *chapter 9.3.3*) by the additional heat source, if one is selected (*chapter 8.3.15.2*), or the backup source (*chapter 9.1.3*). Service has to be called to remove the error.

Error E05 – High Pressure Error

Should within 1 hour pressure in the cooling system of the generator be detected as too high thrice (WARNING W03), the device shuts down and the error needs to be manually acknowledged for a restart (*chapter 8.3.1*).

While the error is triggered, water is heated to Anti-freeze temperature setting (35 °C *chapter 9.3.3*) by the additional heat source, if one is selected (*chapter 8.3.15.2*), or the backup source (*chapter 9.1.3*).

To remove the error, check if there is sufficient water in the water tank of the device. If the error continues to be displayed in spite sufficient water, service has to be called. Heating until the arrival of the service requires a manual activation of the backup source (*chapter 8.3.10*), or alternative mode (*chapter 8.3.3*), if an external source is connected to the system.

Error E07 – External Source Temperature Difference Error

In the case that the system is connected to an external source which the device may activate via electric signal (oil / gas / pellet / wood furnace, external electric heater), the controller checks the temperature of the external source after activation (*chapter 9.2.3*). If the temperature of the external source is not 5°C higher than the temperature of water in the sanitary water tank after three attempts of activation, the controller reports Error E07 and the circulation pump of the external source is deactivated. External source operation needs to be checked. Should external source be functioning flawlessly, service needs to be called. It is not possible to use the external source until the error is removed.

Error E09: Controller supply voltage error

In the case E09 error is displayed on your device, the low-voltage device components (device generator, electric heater, fan ...) cease to operate. The electronics displays error E09 which means a fault in controller supply voltage. The error will be resolved after establishing normal operation voltage and the device will start operating.

10.3 Errors of the OPTITRONIC 2 - WEB module (option):

Error E81 – Error on the connection between WEB module and device controller

To remove error, the cable connecting WEB module and the device (see "Instructions for Error Removal") must be checked. The connection cable needs to be unplugged from the module, checked, and plugged back in. If the cable is damaged or if the error persists after reconnection, call service. Connection to the service Water Cloud is impossible or limited until error removal.

Error E82 – General internal error of the WEB module

To remove the error, the WEB module has to be unplugged from power and re-plugged (see "Instructions for Connection of Device Into Cloud"). If the error persists after module restart, call service. Connection to the service Water Cloud is impossible or limited until error removal.

Error E83 – Memory medium error on the WEB module

To remove the error, the WEB module has to be unplugged from power and re-plugged (see "Instructions for Connection of Device Into Cloud"). If the error persists after module restart, call service. Connection to the service Water Cloud is impossible or limited until error removal.

Error E84 - Error on the communication interface of the WEB module

To remove the error, the WEB module has to be unplugged from power and re-plugged (see "Instructions for Connection of Device Into Cloud"). If the error persists after module restart, call service. Connection to the service Water Cloud is impossible or limited until error removal.

11. Removal and Disposal

The device as a whole, when complying with the instructions for safe use and maintenance, has a set operational time of at least 8 years. Individual components have different operational times, thus, upon potential defects and mechanical damage, they need to be replaced with new ones. Replacements are only allowed with the purchase of technically suitable or original spare parts.

After the operational time expires, the entire device needs to be removed in compliance with valid regulations for waste management. Components that are harmful to the environment need to be deposited at official dangerous materials waste centres.

12. Maintenance and Care

For reliable and efficient operation, the device must be regularly maintained and cared for.



WARNING

Clean device with non-abrasive damp cloth and mild suds.

Use of inappropriate cleaning agents can damage the surface of the device.

It is forbidden to use aggressive cleaning agents, solvents or cleaning agents which contain chlorine.

Regularly check device operation, especially:

- ▶ operation of safety valve on the plumbing
- ▶ cleanliness of the evaporator surface.

If the evaporator surface is dirty, order cleaning from authorised installation technician, who installed the device. We recommend that, along with cleaning, you also order a check of the device.



WARNING

For proper operation of the hot water tank, the device is equipped with an anti-corrosion protection, which protects the device from corrosion and rust, the device must constantly be connected to the power grid. Should the device be unplugged from the power grid, the active anti-corrosion protection will not operate. In such a case, extended warranty on the hot water tank becomes invalid.

13. Errors in Operation

Before calling authorised service, check if:

- ▶ the power supply of the device is carried out directly from the main electrical cabinet
- ▶ the power supply cable from the main electrical cabinet is only connected to this device
- ▶ the power supply cable is undamaged
- ▶ the flow of air through the device is uninhibited (dirt, grille, etc.)
- ▶ the temperature of entry air is higher than the minimal temperature of air where the device generator is still operational.

14. Electrical Connection Scheme

1	Compressor - generator	12	Relay panel
2	Fan	13	Display
3	Electric heater	14	Electromagnetic valves
4	Safety thermostat	15	Fan connection pins
5	Fan capacitor	16	Optical converter
6	Pressure switch	17	High pressure switch relay
7	Temperature probe NTC - water	18	Additional heater connection pin
8	Temperature probe NTC - air	19	Power supply connection pins
9	Temperature probe NTC - evaporator	20	Contactors
10	Connection pins of additional source	21	Web module
11	Compressor capacitor		

15. Technical data

DEVICE		WP4 LF-502
VERSION		
-Heat source		Internal external air
-Controller		Optitronic 2
-Thawing		Active - hot gas circuit
-Electric heater	W	2 x 2000
EFFICIENCY		
-CONDITION		A20W10-55
-Nominal heating power	W	7830 ² (3830 ³ + 2 x 2000)
-Device generator heating power	W	3830
-COP (A20 W10-55) ⁴		3,7
▶ Standard		EN 16147
▶ Exhaust profile		XXL
▶ Use in standby	W	41
▶ Referential water temperature	°C	53,6
▶ Quantity of mixed 40 °C water	l	576
ELECTRICAL DATA		
-Nominal tension, frequency, fuses		~ 230 V; 50 Hz, 16 A ~ 230V; 50 Hz, 25 A ~3N 400 V; 50Hz, 3 x 16 A
-Nominal electrical power	W	980
-Maximal electrical power	W	1506 / 3506 ¹ / 5506 ²
-Protection class		IP21
DIMENSIONS, WEIGHT AND FILLING		
-Dimensions (W x H x D)	mm	792 x 2070 x 870
-Dimensions - packaged (W x H x D)	mm	820 x 2200 x 920
-Mass	kg	240
-Refrigerant - type / quantity of refrigerant	g	R134a / 1800
-Max. pressure permitted in the device	Mpa	2,3 (23 bar)
NOISE		
-Noise power level	dB (A)	65
-Noise pressure level at a distance of 1m	dB (A)	57
RANGE OF OPERATION		
-WATER	°C	10 to 65
-AIR	°C	-7 to 35
NOMINAL FLOW		
-Air	m3/h	800
WATER TANK DATA		
-Volume	l	450
-Highest allowed pressure	Mpa	1,0 (10 bar) at 95 °C
-Volume of heat exchanger	l	11
-Highest allowed working pressure in heat exchanger	Mpa	1,0 (10 bar) at 110 °C
-Surface of heat exchanger	m ²	1,76

¹ Active electric heater 2 kW

² Two active electric heaters 4 kW (2 x 2 kW)

³ Heating power of device generator

⁴ EN 16147 air temperature 20 °C, water heating from 10 °C to 55 °C, relative humidity 70 %

